



# *disan*

*Central vacuum systems*



**HANDBOOK**  
**DS SUPER COMPACT**  
**DS MODULAR RANGE**



**PLANNING • INSTALLATION • TESTING**

© Copyright by DISAN S.r.l.

Technical drawings and layout: Disan S.r.l.

Any unauthorized reproduction, even partial, is forbidden.

---

*Photos, drawings and descriptions in this handbook reflect the state of the art at the moment when this catalogue was printed. The company Disan reserves the right to update its production, previous catalogues and handbooks. For further information, please contact "DISAN"'s technical office.*

*Disan acknowledges a 2 years guarantee for parts having manufacturing defects. The guarantee is valid only if the instructions set out in this handbook are fully complied with.*

---

# TABLE OF CONTENTS

---

|   |           |  |           |
|---|-----------|--|-----------|
| <b>Planning</b>   | <b>4</b>  | <b>Making of the piping</b>  | <b>21</b> |
| Basic planning information .....  | 4         | General instructions .....   | 21        |
| Location of inlet valves on the floor plan .....                                      | 4         | Laying of the tubing .....   | 21        |
| Location of the inlet valves: height .....  | 5         | Laying and connection of<br>the water vacuum system .....                                    | 22        |
| Location of the central vacuum cleaner .....  | 5         | Laying of the backup boxes .....   | 23        |
| Planning of the tubing .....  | 5         | <b>Installation of the breather pipe</b>   | <b>23</b> |
| Planning of the water vacuum system .....   | 7         | <b>Laying of the electric control line</b>   | <b>24</b> |
| Characteristics of the fittings .....   | 8         | <b>Testing</b>   | <b>25</b> |
| Planning of the breather pipe .....   | 8         | Location of losses .....   | 26        |
| Particular requirements of planning .....   | 9         | <b>Installation and connection of the inlet valves and of<br/>the central vacuum cleaner</b> | <b>27</b> |
| Planning of the power mains .....   | 10        | Installation and connection of the inlet valves .....  | 27        |
| <b>Calculation of the materials/Cost-estimate</b>                                     | <b>12</b> | Installation and connection of the central vacuum cleaner .....                              | 28        |
| Definition of the material needed for the tubing .....                                | 12        | Check of the functioning of the by-pass<br>valve on the dust separator .....                 | 31        |
| Choice of the inlet valves and<br>of the electricity plates .....                     | 12        | By-pass valves adjustment .....  | 31        |
| Choice of the cleaning accessories .....  | 16        | Testing of the inlet valves .....  | 32        |
| Approximate calculation of labor for the complete<br>installation of the system ..... | 16        | Final testing of the system .....  | 32        |
| Choice of the central vacuum cleaner .....  | 16        | Delivery of the finished system to the customer .....  | 32        |
| List of optional for mod. DS Super Compact .....                                      | 19        | Certification .....  | 35        |
| List of optional for mod. Ds Modular range .....                                      | 19        |  |           |
| Technical data of the central units .....   | 19        |  |           |

## PLANNING

### Basic planning information

#### Collect all the necessary data for the planning phase

- Type of system (no of simultaneous operators in the whole building and on every floor)
- Special requirements
  - for the piping line
  - for the position of the inlet valves
  - for the position of the central vacuum cleaner
- Voltage and power supply
- Suction of liquids requested (yes/no)
- Plan of the building (floor and section)

#### **! WARNING !**

The central vacuum systems Disan are planned to vacuum the domestic dust both in the domestic and professional sector.

### Location of inlet valves on the plan

#### Planning the inlet valves

Using compasses, draw on the plan (preferably scale 1:100) circles with a radius of 7.5 m, as many as necessary to cover the surface (see example).

**Please notice:** 7,5 m corresponds to the standard range of action of the hose.

- Avoid as much as possible large overlapping of the circumferences.

Z 842

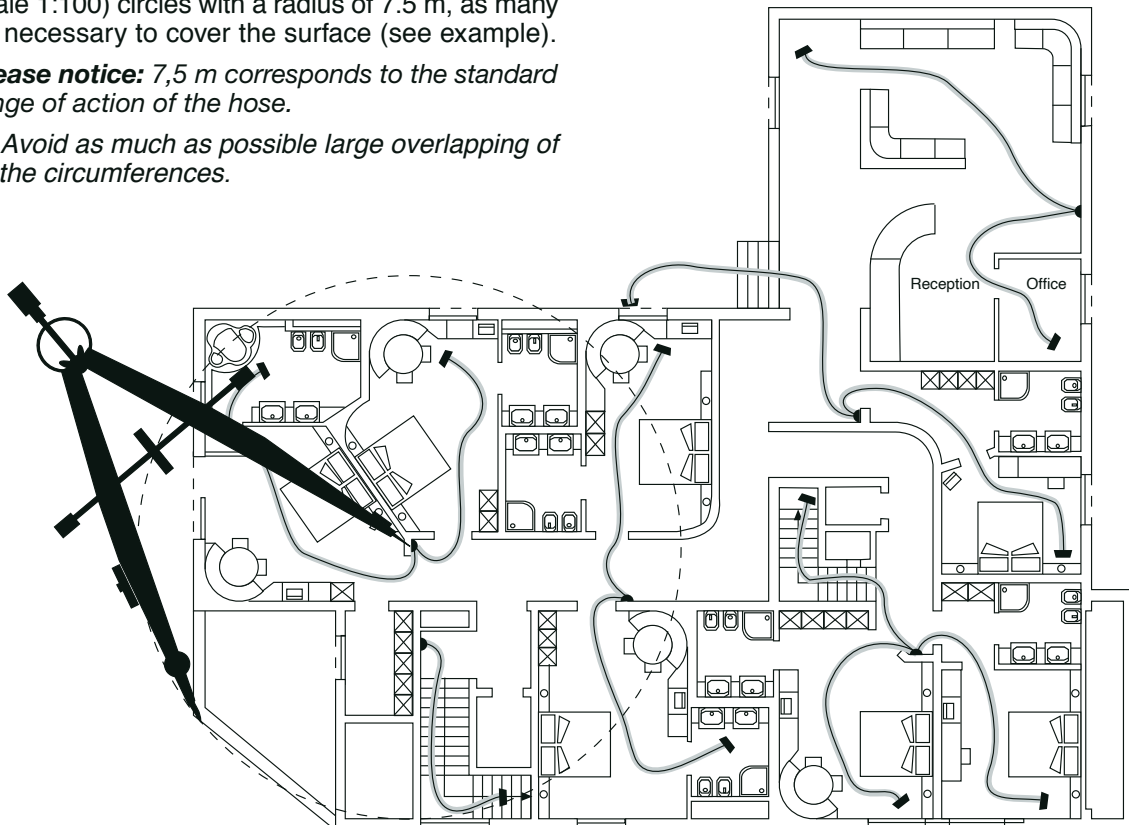

- Preferably point the compasses on the internal walls rather than on the perimeter ones in order to reduce the length of the tubes.
- The convenience of the system is due to the limited number of inlet valves positioned in the right places. (We advise against installing one socket in each room).
- Consider all the possible obstacles (such as walls, pieces of furniture etc.) which reduce the range of action of the hose.
- Consider the difficulty of installing inlet valves on bearing walls or pillars.

#### **Please notice:**

- We suggest to install a socket just at the bottom of the stairs to permit to clean it from the bottom to the top.
- In the rooms which do not require frequent cleaning, such as the garage, the cellar etc., a 2 m flexible extension can be used (included in the Deluxe kit of accessories) which extends the range of action to 9.5 m.
- We suggest to install a socket in the garage and near balconies or floored entrances.

## Central vacuum systems

### Location of the inlet valves: height

Install the inlet valves at the same height of electricity sockets or switches.

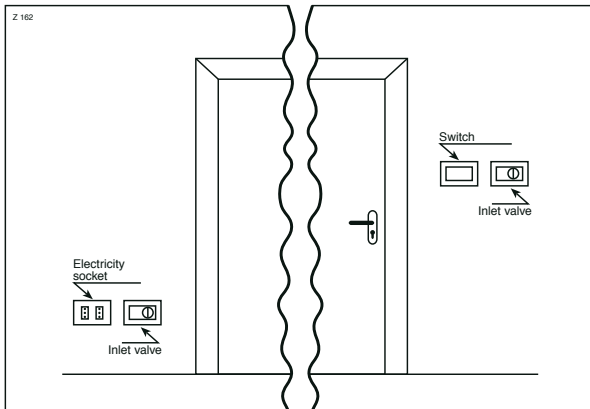

Square inlet valves or rectangular are available and are compatible with the most popular brands on the market.

### Location of the central vacuum cleaner

The central vacuum cleaner has to be located into the cellar, the storeroom, the garage or the hobby-room, and in any case you have to guarantee a sufficient air-circulation for its cooling. Consider the acoustic and thermal emissions of the turbine motor.

- The central vacuum cleaner should preferably be located at the lowest point of the tubing, in order to guarantee that even the heaviest vacuumed material is transported through the tubes to the central vacuum cleaner.

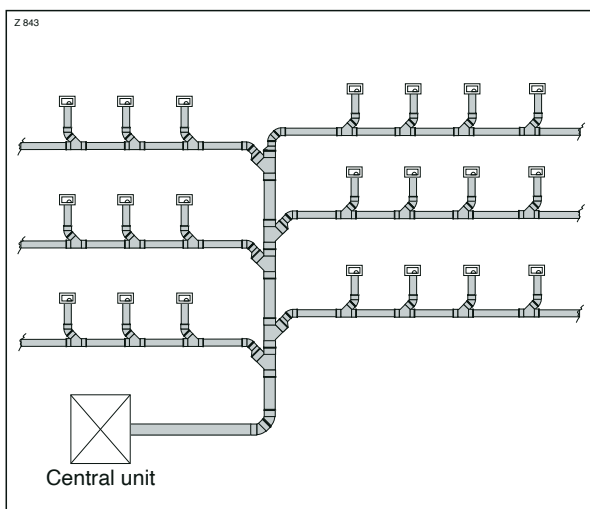

If it is not possible to install the central unit on the lowest point of the tubing, please contact the technical office Disan.

### Planning of the tubing

Optimal suction depends on the tubing which should be as short and linear as possible. As a consequence, variations in the route should be avoided as much as possible.

- If possible, the vertical descent should be at a central point of the house.
- The tubing can be fitted under-track, inside the walls or on the false ceiling
- When many simultaneous operators join together, install the reducer as in the drawing on page 6

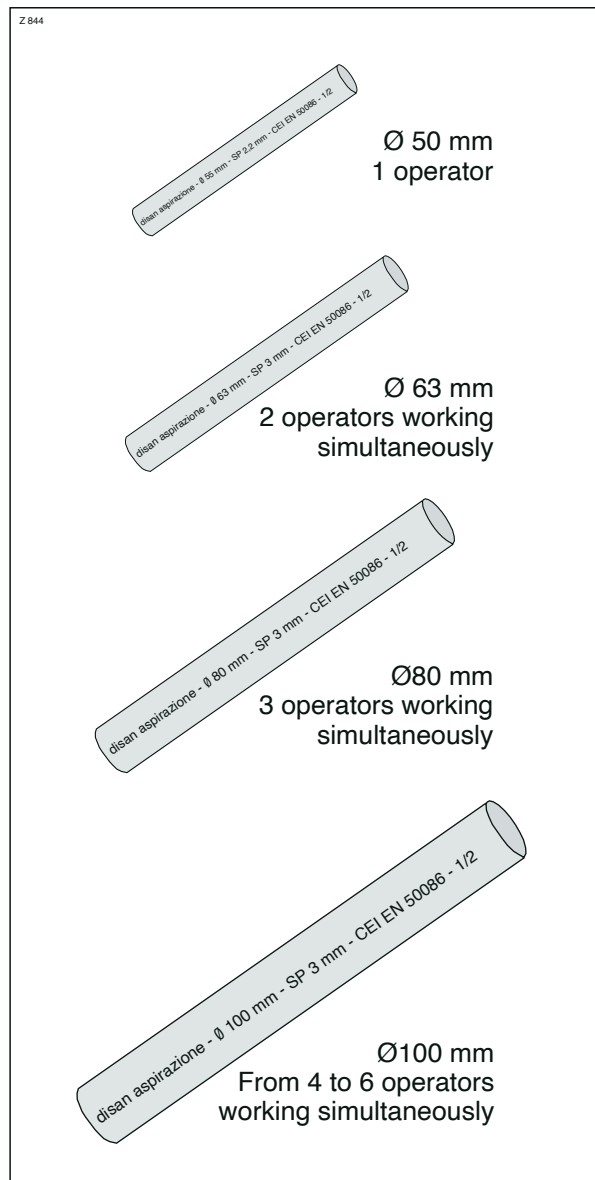

# Central vacuum systems

**Scheme of distribution of the pipe line for a system of 6 operators**

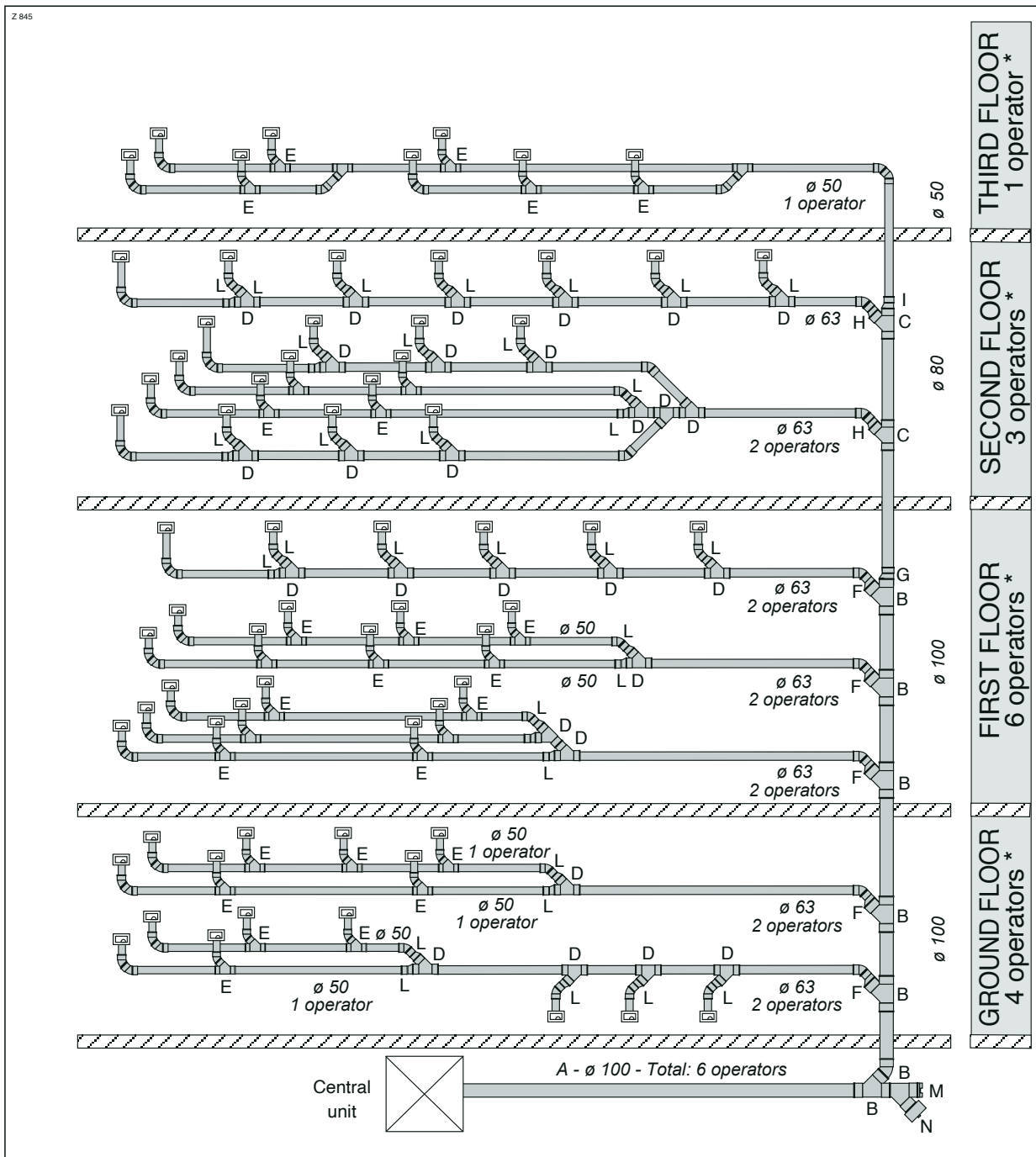

- A = horizontal pipe at the vertical descend  $\varnothing 100 - 63 - 6$  operators \* the maximal simultaneousness of the floors can not be added
- B = sweep TY  $\varnothing 100 - 63 - 6$  operators
- C = sweep TY  $\varnothing 80 - 3$  operators
- D = sweep TY  $\varnothing 63 - 2$  operators
- E = sweep TY  $\varnothing 50 - 1$  operator
- F = sweep reducer  $\varnothing 100/63 -$  from 4/6 to 2 operators
- G = sweep reducer  $\varnothing 100/80 -$  from 4/6 to 3 operators
- H = sweep reducer  $\varnothing 80/63 -$  from 3 to 2 operators
- I = sweep reducer  $\varnothing 80/50 -$  from 3 to 1 operator
- L = sweep reducer  $\varnothing 63/50 -$  from 2 to 1 operator
- M = inspection cap  $\varnothing 100$
- N = By-pass valve  $\varnothing 100$

The horizontal pipe line on the floor requests a maximal diameter of 63 mm (2 operators working simultaneously). In the case it is necessary to vacuum on the same floor with more than 2 operators, split the pipe line on the floor into zones.

## Central vacuum systems

- In the big systems it's advisable to have as many descents as the zones or the building floors and to connect them near the central unit. Install on every descent a sphere valve with manual closing. This allows, in case of assistance on a line, the use of the rest of the system, helping any interventions.

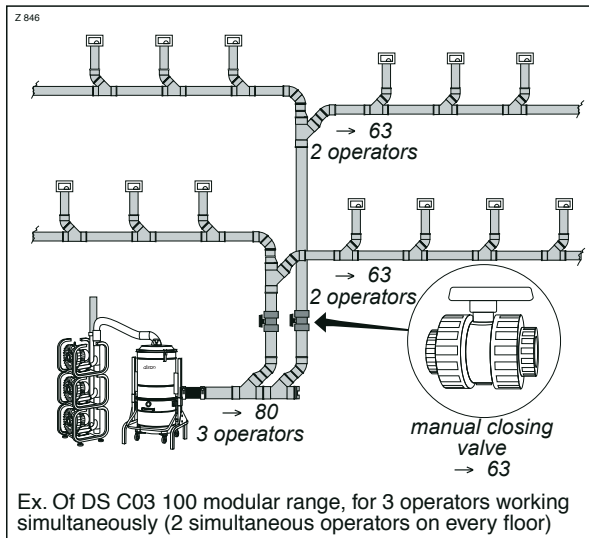

In the case of a single descent the valve with manual closing is not necessary.

- It is not advisable to install long horizontal lines of diameter 80 mm and 100 mm. If on these lines works a smaller number of simultaneous operators than that for which it was planned some clogging are possible.

In the cases in which the installation of these diameters is impossible to avoid, plan in the more distant point of the horizontal line a sweep TY in order to be connected to an inspection cap.

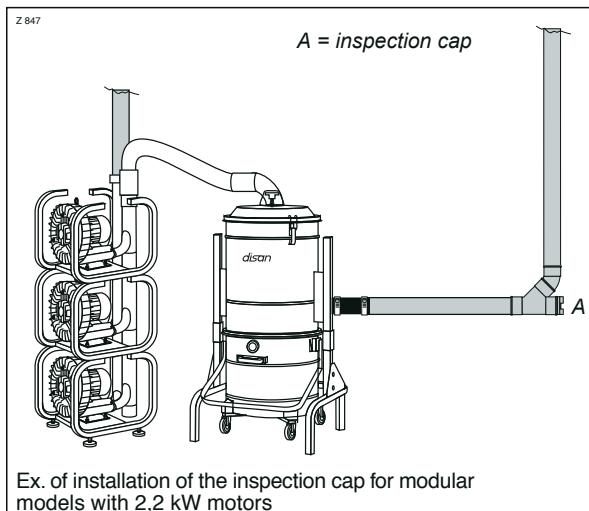

In the 5,5 kW models besides the inspection cap install a by-pass valve.

The inspection cap makes easier an eventual assistance intervention.

The by-pass valve allows the cleaning of the piping. In this case the by-pass valve on the dust separator must be closed in order to allow the valve functioning on the line.

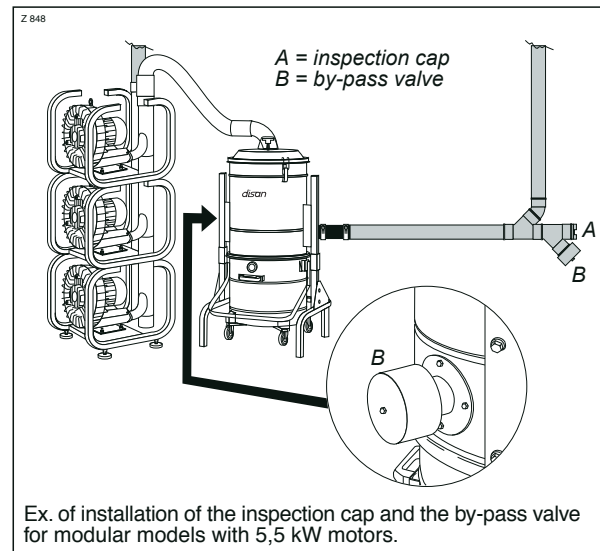

### Planning of the water vacuum system

The water vacuum is possible thanks to its special accessory "wet pick-up" (code SZN348) to be dragged during the cleaning, or through an autonomous pipe line, which collects the water into a separator (code SZN361) placed near the central unit.

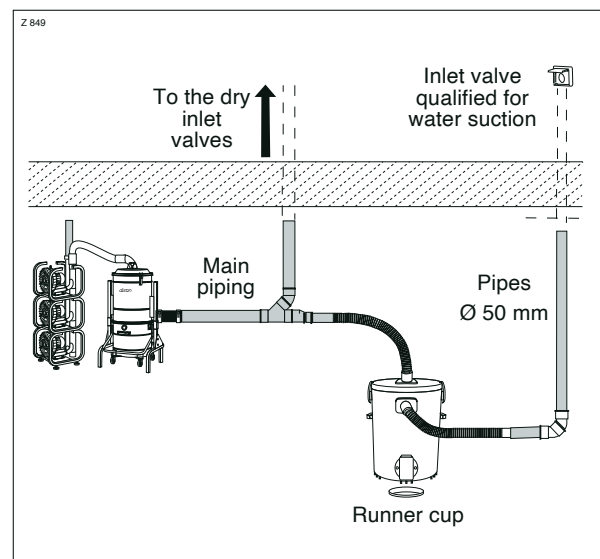

# Central vacuum systems

- Plan the inlet valves in the rooms where you intend to vacuum the water. Connect between them the inlet valves with a piping diameter 50 mm, to join to the pipe fittings equipped with the wet pick-up.
- Plan a runner cap with a minimum diameter of 40 cm, to be placed in front of the separator, where the vacuumed water will be carried.
- Connect the wet pick-up to the main pipe line of the system.

**Please notice:**

- In the rooms where one intends to vacuum both dry and damp, install 2 separate inlet valves
- The water vacuum system can be used only by a person at time

### Characteristics of the fittings

In order to obtain maximum suction performances, the tubes have to be installed in an air-tight way.

Clutch fittings are not sufficiently tight in the long run and for this reason we advise against using them.

**We strictly advice against:**

- fittings with rubber gaskets or with O-rings
- spigot-and-socket joint fittings
- hot-welded fittings

**Please notice:** using the types of fittings listed above causes the following problems:

- depression reductions due to the progressive decrease in tightness of the rubber gaskets or O-rings;
- clogging due to step-like obstacles or burrs inside the tubes;
- speed-reduction of the air-flow due to step-line obstacles or slight defects inside the tubes;
- whistles due to air-infiltrations inside the tubing caused by the progressive decrease in the tightness of the rubber gaskets or O-rings;
- whistles due to steps inside the tubes.

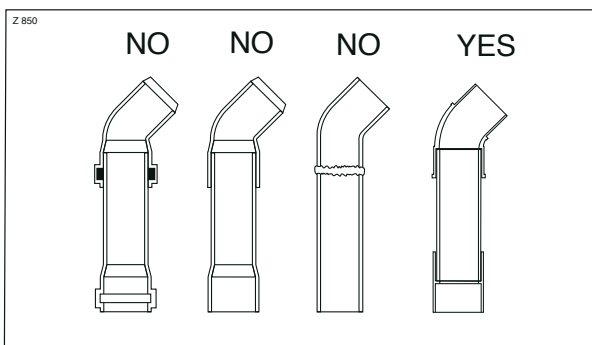

**Use only 45° or 90° wide radius sweep.**

“T” sweeps slow down the flow and cause clogging.

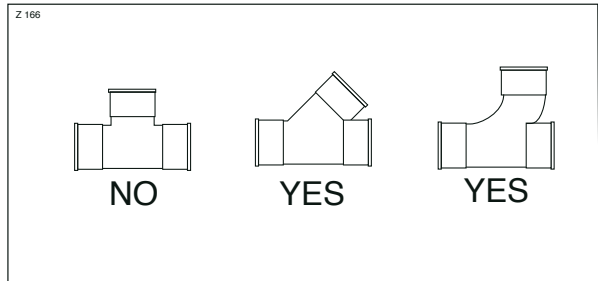

**Use only 45° or 90° wide radius sweep ell.**

Exception: there is only one 90° (narrow radius) sweep ell: which is positioned behind the backup box.

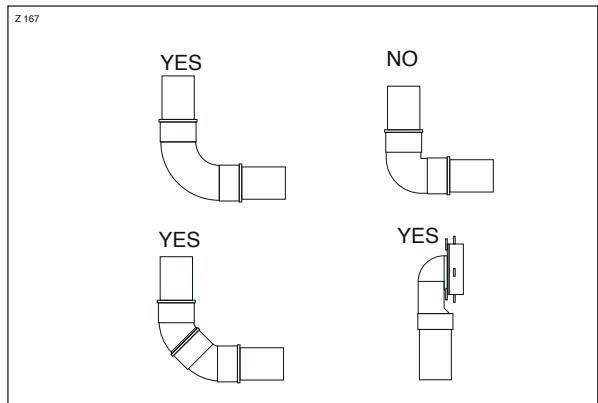

**Please notice:** planning the tubes so that the suction flow follows a horizontal or sloping route. Avoid long upwards suction flows.

### Planning of the breather pipe

The central vacuum cleaners *Disan* have a correct air filtering, with environmental protection, and so the breather pipe is not strictly necessary. However, for hygienic reasons, we suggest to install it. The breather pipe shall have a larger diameter of the main line of the system.



## Central vacuum systems

|   |    |     |     |     |
|---|----|-----|-----|-----|
| Diameter of the main line                             | 50 | 63  | 80  | 100 |
| Diameter of the breather pipe for lengths less than 5 | 63 | 80  | 100 | 100 |
| Diameter of the breather pipe for lengths more than 5 | 80 | 100 | 125 | 125 |

### Silencer

All the turbines used in the central vacuum systems *Disan* are silenced with soundproofing materials at the end of the suction and of the delivery, in order to maintain a sound level lower than the levels previewed by the regulations.

The models DS Super Compact are equipped with an additional silencer, mounted on the internal part of the central unit.

Optional silencer are available in order to reduce the noisiness produced by the motors. The silencer must be mounted on the end of the breather pipe (with whichever inclination), in order to allow the absorption of all the noises produced in the piping. The zinc-coated silencer is available in the following models, to be chosen on the basis of the diameter used on the breather pipe.

- Zinc-coated silencer diam. 70/63 mm complete with 2 zinc-coated couplings Code IS10
- Zinc-coated silencer diam. 100 mm complete with 2 zinc-coated couplings Code IS11

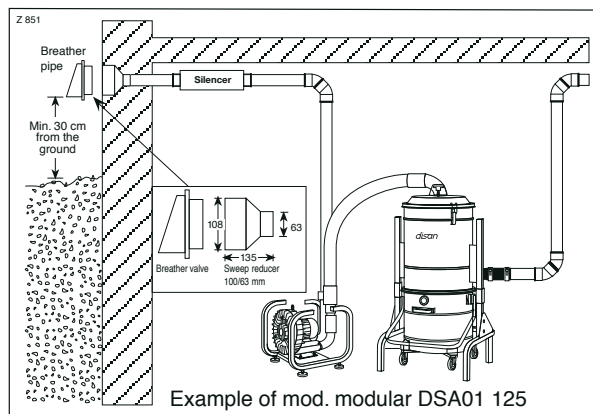

### Particular requirements of planning

In the case in which the piping crosses structures where there are dilatation joints or it connects 2 different structures use the following items:

- Dilatation joint in order to give flexibility to the piping
- Covering in thermal insulating material (normally used in the hydraulic field) to avoid condensate problems and to give flexibility to the piping in the case of settlements of the building or of the ground.

If the piping is installed externally to the building and underground, plan a container barrier.

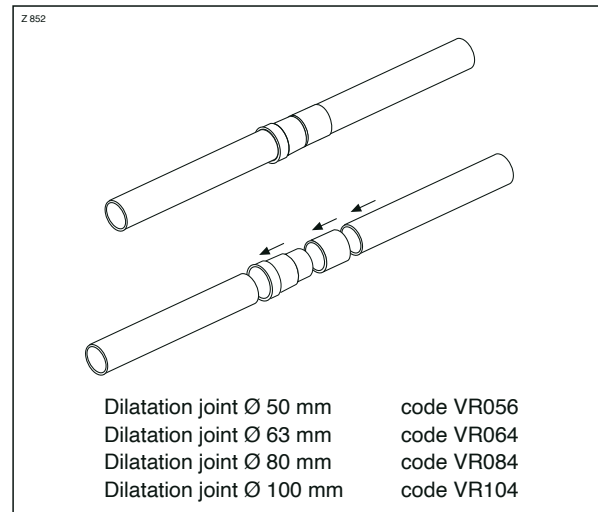

In the case that the pipe line crosses the fire barrier structure, plan the special collars for wall or floor.

- Wall: 2 collars (one for every side)
- Floor: 1 collar on the lower side

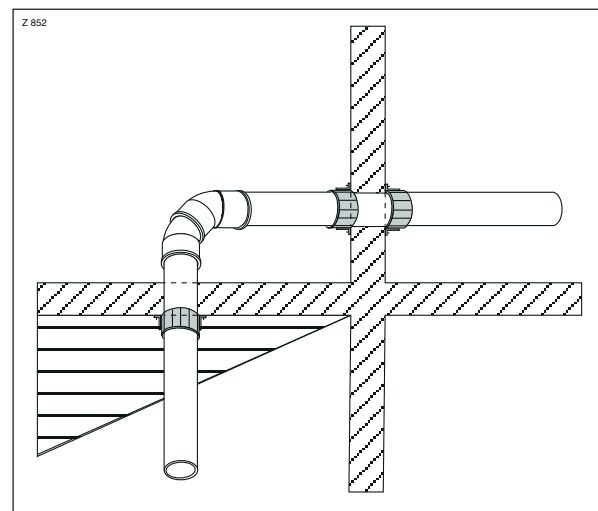

### ! WARNING !

Do not install external piping in contact with sunbeams and atmospheric agents. In these cases we advise to use zinc-coated stainless steel tubes. Contact the technical office *Disan*.

If it is not possible to avoid the installation of external tubes, cover the tube with thermal insulating material (normally used in the hydraulic field).

# Central vacuum systems

## Planning of the power mains

The power mains used for the control of the inlet sockets is 12 V (safety low-voltage) and permits to start the central vacuum cleaner through a contact on the sockets.

The covering supplied by *Disan* is fireproof according to IMQ standards; it has a 16 mm diameter, while the two internal cables have a 1 mm diameter.

The connections between the inlet valves are in parallel in the backup box with binding-screw.

### Systems up to 30 inlet valves

The connection is from inlet valve to inlet valve to the main electric junction box.

### Systems with more than 30 inlet valves

We advise to split the system into zones or for floors, connecting them separately to the electric division box for 12V remote control wire. (code IE212) and to the main electric junction box. In this way it will be easier to find out any damage to the line (see drawing on the next page).

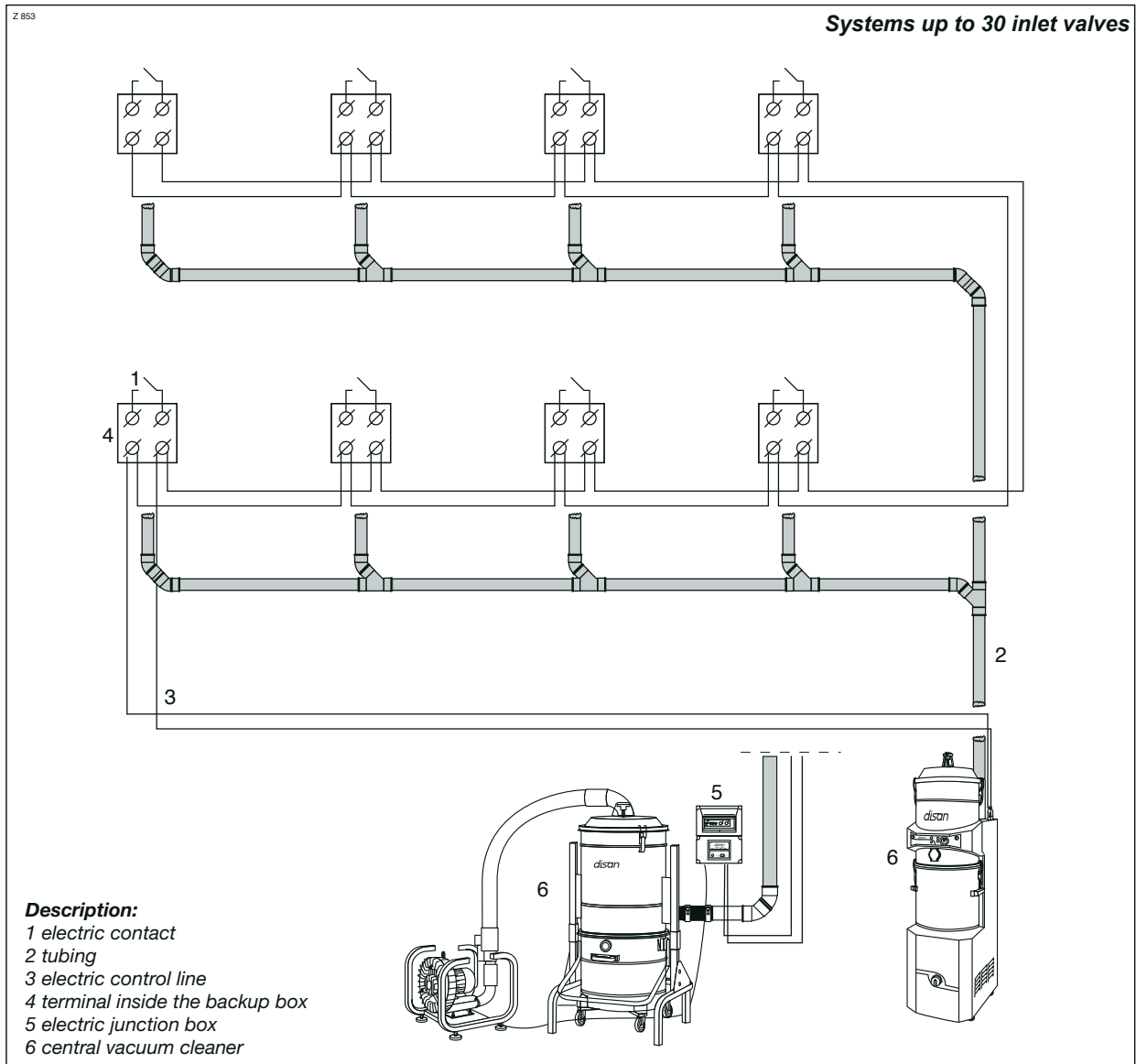

## Central vacuum systems

### Use of the system with sequential starting device

This kind of system allows the sequential starting device of motors requested. It comes a real energy saving.

For the functioning of the sequential starting system, install inlet valves equipped with resistances (IS106) to be welded on the electrical cable at the output of the inlet valve. The connection of the line is always in parallel.

If the resistance is ordered with the inlet valve please add "R" at the end of the code of the valve. Ex: SD310R. For the functioning of the sequential starting device system you need the special electronic control. For the functioning of the system

it is necessary that both the resistances and the electronic control device are mounted.

Code IS02 device for models with 2 motors (Mod. DS B02 and DS D02)

Code IS03 device for models with 3 motors (Mod. DS C03 and DS F03)

### Suggestions for extended systems

With the models DSA01 and DSB01 mount the resistances on the inlet valves and the electronic control device only when it is planned to extend the system.

With the models DSB02 and DSD02 we suggest to install at once the device for 3 motors.

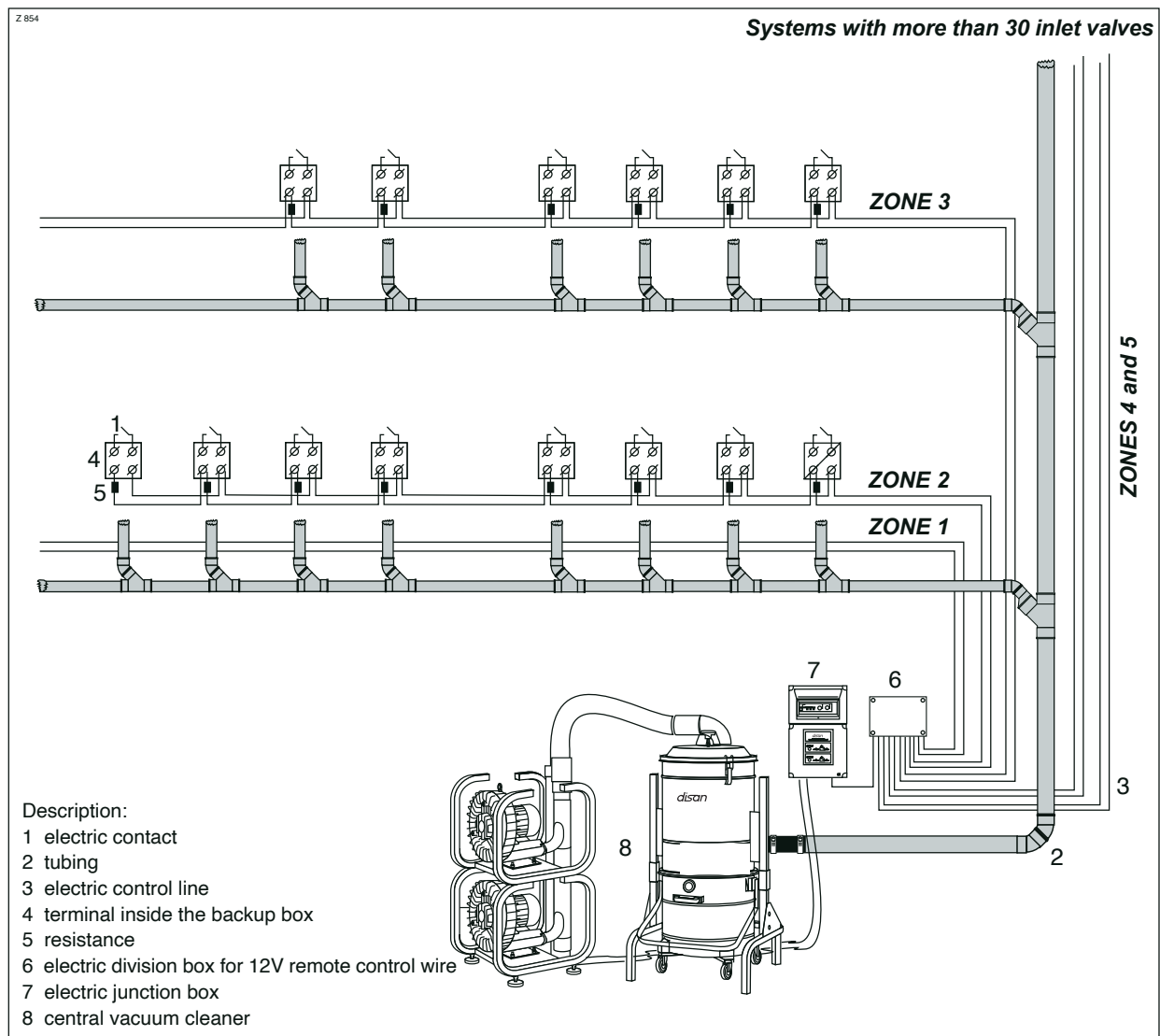

### CALCULATION OF THE MATERIALS/COST-ESTIMATE

#### Definition of the material needed for the tubing

The following table indicates the material needed approximately, based on the number of inlet valves established in the planning phase.

From these amounts the material about the diameters 63, 80 and 100 mm must be deducted which will be separately calculated on the plan.

**Please notice:** the calculation of the materials in the table is approximate. In case of special conditions in the distribution of the tubing (unusual routes) - for instance if the central vacuum cleaner is positioned far away from the inlet sockets - please ask *Disan's* technical office for advice.

| Inlet valve         | Backup box          | PVC pipe length 2m<br>Ø 50 mm | 45° PVC sreet ell Ø 50 mm | 45° PVC sweep ell Ø 50 mm | 45° PVC sweep TY Ø 50 mm | PVC coupling Ø 50 mm | Remote control wire 25 m **** | PVC adhesive 125 gr tube | PVC adhesive 500 gr can | Breather valve complete with reducer Ø 50 mm | Tight junction box | Wire clamp 30 cm | Collars made of stainless steel Code*** KM501 |
|---------------------|---------------------|-------------------------------|---------------------------|---------------------------|--------------------------|----------------------|-------------------------------|--------------------------|-------------------------|--|--------------------|------------------|---|
| See following pages | See following pages | Code VR050                    | Code VR051                | Code VR052                | Code VR053               | Code VR055           | Code EM025                    | Code KM125               | Code KM500              | Code VR058                                   | Code* EM31/EM32    | Code** EM033     | Code*** KM501                                 |
| 1                   | 1                   | 5 (10 m)                      | 3                         | 3                         |                          | 2                    | 1                             | 1                        |                         | 1  | 1                  | 9                | 6   |
| 2                   | 2                   | 8 (16 m)                      | 6                         | 6                         | 1                        | 4                    | 1                             | 1                        |                         | 1  | 1                  | 16               | 11  |
| 3                   | 3                   | 11 (22 m)                     | 9                         | 9                         | 2                        | 6                    | 2                             | 2                        |                         | 1  | 1                  | 23               | 15  |
| 4                   | 4                   | 15 (30 m)                     | 12                        | 12                        | 3                        | 8                    | 2                             | 2                        |                         | 1  | 1                  | 30               | 20  |
| 5                   | 5                   | 18 (36 m)                     | 15                        | 15                        | 4                        | 10                   | 2                             |                          | 1                       | 1  | 1                  | 36               | 24  |
| 6                   | 6                   | 21 (42 m)                     | 18                        | 18                        | 5                        | 12                   | 3                             |                          | 1                       | 1  | 1                  | 43               | 29  |
| 7                   | 7                   | 25 (50 m)                     | 21                        | 21                        | 6                        | 14                   | 3                             |                          | 1                       | 1  | 1                  | 50               | 33  |
| 8                   | 8                   | 28 (56 m)                     | 24                        | 24                        | 7                        | 16                   | 4                             |                          | 1                       | 1  | 1                  | 57               | 38  |
| 9                   | 9                   | 31 (62 m)                     | 27                        | 27                        | 8                        | 18                   | 4                             | 1                        | 1                       | 1  | 1                  | 63               | 42  |
| 10                  | 10                  | 36 (72 m)                     | 30                        | 30                        | 9                        | 20                   | 4                             | 1                        | 1                       | 1  | 1                  | 72               | 48  |
| 11                  | 11                  | 39 (78 m)                     | 33                        | 33                        | 10                       | 22                   | 5                             | 2                        | 1                       | 1  | 1                  | 79               | 53  |
| 12                  | 12                  | 42 (84 m)                     | 36                        | 36                        | 11                       | 24                   | 5                             | 2                        | 1                       | 1  | 1                  | 86               | 57  |
| 13                  | 13                  | 46 (92 m)                     | 39                        | 39                        | 12                       | 26                   | 6                             |                          | 2                       | 1  | 1                  | 93               | 62  |
| 14                  | 14                  | 50 (100 m)                    | 42                        | 42                        | 13                       | 28                   | 6                             |                          | 2                       | 1  | 1                  | 99               | 66  |
| 15                  | 15                  | 52 (104 m)                    | 45                        | 45                        | 14                       | 30                   | 6                             |                          | 2                       | 1  | 1                  | 106              | 71  |

\* EM031 tight junction box/EM032 Junction box

\*\* EM033 wire clamp 30 cm - 1 every meter of tube

\*\*\* KM501 collar with anchor diameter 50 mm (for tubes over the plastering) – 1 every 1.5 m of tube

\*\*\*\* EM025 remote control wire – 1,3 m for every metre of tube

#### Choice of the inlet valves and of the electricity plates

Choose the model of inlet valve based on the furniture. Please consider that the available inlet valves are similar to those of the most common brands of electric sockets (square or rectangular). For systems for the industrial sector we advise the inlet valves with pin-jacks.

**Please notice:** for each type of inlet valve there is a backup box. Inlet valves and kits of cleaning accessories are interdependent.

See "Choice of the cleaning accessories" on page 16.

### RECTANGULAR INLET VALVES AND BACKUP BOXES MOD. UNIVERSAL

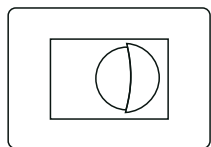

Inlet valve  
Mod. "Universal"  
(decorative electric  
plates are not  
included)

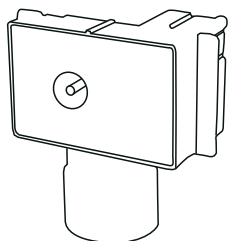

Backup box with  
90° ell code  
SD101

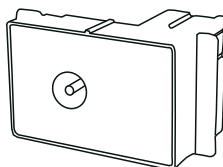

Backup box with  
straight coupling  
code SD102



Universal extension  
code SD802

- Inlet valve for bTicino Living International  
Black colour  
**Code SD110**
- Inlet valve for bTicino Luna and Matix  
White colour  
**Code SD113**
- Inlet valve for bTicino Light  
White colour  
**Code SD113**
- Inlet valve for bTicino Light Tech  
Grey Tech colour  
**Code SD114**
- Inlet valve for Vimar Idea and Rondò  
Ivory colour  
**Code SD121**
- Inlet valve for Vimar Idea and Rondò  
Black colour  
**Code SD120**
- Inlet valve for Vimar Plana  
White colour  
**Code SD113**
- Inlet valve for Ave Banquise  
White colour  
**Code SD132**
- Inlet valve for Ave System 45  
Black colour  
**Code SD130**
- Inlet valve for Legrand, Vela, Cross  
White colour  
**Code SD150**
- Inlet valve for Gewiss Playbus Young  
Black colour  
**Code SD140**

### BACKUP BOXES FOR PANEL WALLS

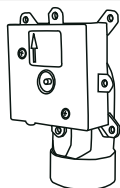

- Backup box with 90° ell  
**Code SD504**

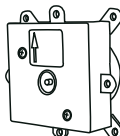

- Backup box with straight coupling  
**Code SD505**



- Minimum extension (1,8 cm)  
for square inlet valve  
**Code SD824**

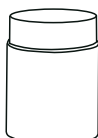

- Extension (5 cm) for  
square inlet valve  
**Code SD822**

## Central vacuum systems

Z 650

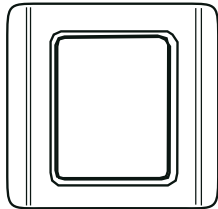

Inlet valve DISAN Mod. OLYMPIA  
With microswitch or pin-jacks

Z 172

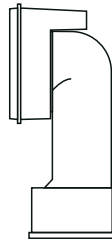

Backup box  
for inlet valve  
Mod. OLYMPIA

Inlet valve with microswitch white colour,  
with decorative trims:

|          |              |
|----------|--------------|
| - white  | Code SD530OW |
| - gold   | Code SD530OG |
| - silver | Code SD530OS |
| - nickel | Code SD530OB |

Inlet valve with pin-jacks, white colour, with decorative  
trims:

|          |              |
|----------|--------------|
| - white  | Code SD531OW |
| - gold   | Code SD531OG |
| - silver | Code SD531OS |
| - nickel | Code SD531OB |

Backup box 90° with ell

|                  |            |
|------------------|------------|
| - under plaster  | Code SD501 |
| - for panel wall | Code SD504 |

Backup box with straight coupling

|                  |            |
|------------------|------------|
| - under cover    | Code SD502 |
| - for panel wall | Code SD505 |

Extension for inlet valve 2,2 cm

Code SD824

Frame for inlet valve

Code SD825

Decorative trims:

|          |         |
|----------|---------|
| - white  | Code OW |
| - gold   | Code OG |
| - silver | Code OS |
| - nickel | Code OB |

Z 653

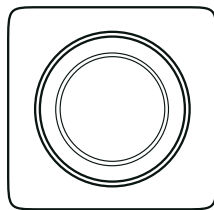

Inlet valve DISAN mod. ROYAL  
With microswitch or pin-jacks

Z 172

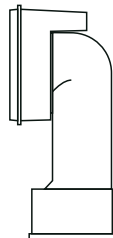

Backup box  
for inlet valve  
mod. ROYAL

Inlet valve with microswitch white colour, with  
decorative trims:

|          |              |
|----------|--------------|
| - white  | Cod. SD520OW |
| - gold   | Cod. SD520OG |
| - silver | Cod. SD520OS |
| - nickel | Cod. SD520OB |

Inlet valve with pin-jacks, white colour, with decorative  
trims:

|          |              |
|----------|--------------|
| - white  | Cod. SD521OW |
| - gold   | Cod. SD521OG |
| - silver | Cod. SD521OS |
| - nickel | Cod. SD521OB |

Backup box 90° with ell

|                  |            |
|------------------|------------|
| - under plaster  | Cod. SD501 |
| - for panel wall | Cod. SD504 |

Backup box with straight coupling

|                  |            |
|------------------|------------|
| - under cover    | Cod. SD502 |
| - for panel wall | Cod. SD505 |

Extension for inlet valve 2,2 cm

Cod. SD822

Frame for inlet valve

Cod. SD825

Decorative trims:

|          |         |
|----------|---------|
| - white  | Cod. OW |
| - gold   | Cod. OG |
| - silver | Cod. OS |
| - nickel | Cod. OB |

**Please notice:** add "R" to the codex of the inlet valve if the resistance is requested.

### FLOOR INLET VALVE

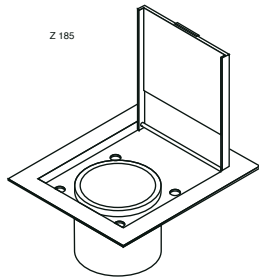

Wall and floor inlet valve DISAN mod. METAL in stainless steel with pin-jacks

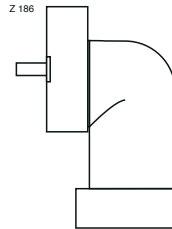

Backup box for inlet valve mod. METAL

|   |            |
|---|------------|
| Floor inlet valve with pin-jacks                    | Code SD911 |
| Backup box with 90° ell                             | Code SD901 |
| Backup box with straight coupling                   | Code SD902 |
| Extension for inlet valve in stainless steel 2,5 cm | Code SD801 |

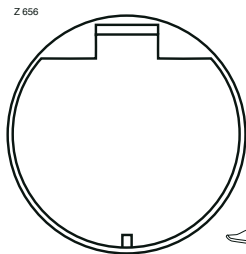

Floor inlet valve with microswitch

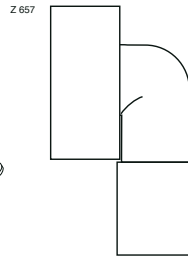

Backup box for inlet valve DISAN

|  |            |
|--|------------|
| DISAN Floor inlet valve with microswitch   | Code SD915 |
| Key for floor inlet valve                  | Code SD919 |
| Backup box with 90° ell                    | Code SD914 |
| Backup box with straight coupling          | Code SD918 |
| Frame for inlet valve - in stainless steel | Code SD926 |
| - black colour                             | Code SD925 |

### UTILITY VALVES

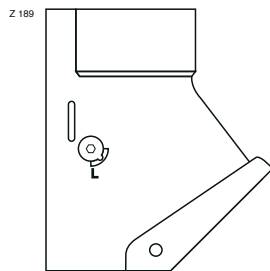

Utility valve DISAN mod. FREE with switch

|                                |            |
|--------------------------------|------------|
| Utility valve grey with switch | Code SD720 |
|--------------------------------|------------|

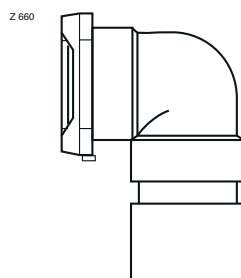

Utility valve DISAN mod. HOBBY with pin-jacks

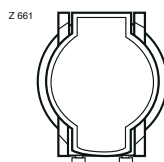

|   |            |
|---|------------|
| Utility valve white with pin-jacks and with 90° ell           | Code SD724 |
| Utility valve white with pin-jacks and with straight coupling | Code SD723 |

**Please notice:** Add „R“ to the codex of the inlet valve if the resistance is requested.

### Choice of the cleaning accessories

| CHOICE OF THE CLEANING ACCESSORIES | CODE    |
|------------------------------------|---------|
| <b>Deluxe set</b>                  |         |
| with flexible 7,5-m-hose           | SZN301  |
| with flexible 9-m-hose             | SZN303  |
| <b>Deluxe Super set</b>            |         |
| with flexible 7,5-m-hose           | SZN301S |
| with flexible 9-m-hose             | SZN303S |
| with flexible 11-m-hose            | SZN305S |
| <b>Standard set</b>                |         |
| with flexible 7,5-m-hose           | SZN302  |
| with flexible 9-m-hose             | SZN308  |
| <b>Standard Super set</b>          |         |
| with flexible 7,5-m-hose           | SZN302S |
| with flexible 9-m-hose             | SZN308S |
| <b>Garage set</b>                  |         |
| with flexible 9-m-hose             | SZN307  |
| <b>Animal care tools</b>           |         |
| with flexible 9-m-hose             | SZN347  |
| <b>Professional set</b>            |         |
| with flexible 9-m-hose             | SZN309  |

See *Disan* general catalogue, *Disan* price list and *Disan* instructions of use.

**Please notice:** inlet valves and cleaning accessories are interdependent. If you choose cleaning tools with on-off switches on the handle of the hose, you necessarily have to install inlet valves with pin-jacks.

### Approximate calculation of labour for the complete installation of the system

Approximate estimate of the working hours needed to install a system with 15 inlet valves. If the system has more inlet valves, use as model the needed hours with a proportional calculation of the hours in the schedule.

| INLET VALVES | LABOUR HOURS |
|--------------|--------------|
| 1            | 6            |
| 2            | 8,30         |
| 3            | 10,30        |
| 4            | 12,30        |
| 5            | 15           |
| 6            | 17           |
| 7            | 19           |
| 8            | 21,30        |
| 9            | 23,30        |
| 10           | 25,30        |
| 11           | 29           |
| 12           | 31           |
| 13           | 33           |
| 14           | 35,30        |
| 15           | 37,30        |

### Choice of the central vacuum cleaner

#### Decisive factors in the choice of a central unit.

1. the number of operators working simultaneously
2. the pipe length.

If we consider that in normal condition every 1,000 m<sup>2</sup> of surface works 1 operator, the length of the tubes is lower than the vacuum power of the motors. In a building of 1,500 m<sup>2</sup> you need about 30 inlet valves and about 300 m of hose. Airlosses calculation are not requested if we consider this indication. If not so please contact the technical office *Disan*.

3. the quantity of dust that is vacuumed. In the buildings with many people (offices, banks, hotels, theatres, etc.) we advise dust container capacity in order to avoid many emptying.

#### Considerations about the number of operators working simultaneously needed

From the graph we can deduce that in normal conditions the attendants do not work simultaneously on the system.

If in a hotel work 6 attendants, on average the system is used by 4 operators at the most, while the other 2 persons do other works.

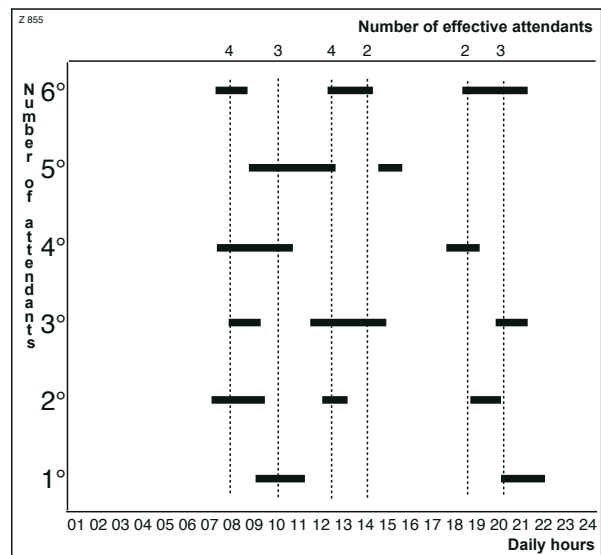



### Models available for number of operators:

#### 1 operator



- Mod. DS Super Compact 1,5** **Code 6405**  
 This single-phase model is advised in the buildings with max. surface of about 700 m<sup>2</sup>. In the buildings with less surface it can be a valid alternative to the single-phase units of ZSA range, when a greater suction power is needed and especially a reduction of maintenance thanks to the automatic filter shaker. The model is compact and all the components (electric control panel included) allow a space reduction and a quick installation.
- Mod. DS Super Compact 2,2** **Cod. 6406**  
 This three-phase model is advised in the buildings with max. surface of about 1,000 m<sup>2</sup>. The model is compact and all the components (electric control panel included) allow a space reduction and a quick installation.
- Mod. DS A01 100 I** **Cod. A100**  
**Mod. DS A01 125 I** **Cod. A125**  
 This three-phase modular model is advisable in buildings with max. surface of about 1,000 m<sup>2</sup>. Unlike the model DS Super Compact 2,2 the model DSA01 uses dust separators of bigger capacity, to avoid the frequent emptying of the dust container. Furthermore this model can be enlarged to 2 or 3 operators working simultaneously. In this case also the diameters of the tubes shall be suitable to allow more operators working simultaneously.

#### 2 operators working simultaneously



- Mod. DS Super Compact Turbo 2,2 single-phase** **Code 6409**  
 This single-phase model is advised in the buildings with max. surface of about 1,000 m<sup>2</sup>. The model is compact and all the components (electric control panel included) allow a space reduction and a quick installation.
- Mod. DS Super Compact Turbo 4,5i** **Code 6408**  
 This compact three-phase model is advised in the buildings with max. surface of about 2,000 m<sup>2</sup>. The frequency converter allows a suitable suction for 3 kW motor on the kind of filtering surface and on the numbers of operators working on the system. To be operating fully the motor absorbs 4,5 kW. This inverter differs from the others because it modulates the motor power in more than 100 values, thanks to a depression transducer. The model is compact and all the components (electric control panel included) allow a space reduction and a quick installation.

- Mod. DS B01 100 I** **Code B100ST**  
**Mod. DS B01 125 I** **Code B125ST**  
 This three-phase model is advised in the buildings with max. surface of about 2,000 m<sup>2</sup>. Unlike the model DS Super Compact 4,5 Turbo the model DSB01 uses dust separators of bigger capacity, to avoid the frequent emptying of the dust container. Furthermore this model can be enlarged to 4 or 6 operators working simultaneously. In this case the diameters of the tubes shall be suitable to allow more operators working simultaneously.
- Mod. DS B02 100 I** **Cod. B200**  
**Mod. DS B02 125 I** **Cod. B225**  
 This three-phase model is advised in the buildings with max. surface of about 2,000 m<sup>2</sup>. Unlike the model DS Super Compact 4,5 Turbo the model DSB02 uses dust separators of bigger capacity. This model is preferable to the model DS B01 in the case in which the use of 2 operators working simultaneously is not frequent. It is possible an energy savings thanks to the sequential starting device for motors.  
 Example: in a small hotel during high season work 2 operators simultaneously while during low season the system needs just one operator. This kind of system allows, if requested, the starting of just one motor and an energy saving. This model can be enlarged to 3 operators working simultaneously. In this case the diameters of the tubes shall be suitable to allow more operators working simultaneously.

#### 2-3 operators working simultaneously



- Mod. DS BC 100i** **Cod. BC100i**  
 This three-phase model is advised in the buildings with max. surface of about 2,500 m<sup>2</sup>. The frequency converter allows the adaptation at the kind of cleaning surface or at the number of operators. The model is compact and all the components (electric control panel included) allow a space reduction and a quick installation.

### 3 operators working simultaneously



- **Mod. DS C03 100 I** Code C100  
**Mod. DS C03 125 I** Code C125  
 This three-phase model is advised in the buildings with max. surface of about 3,000 m<sup>2</sup>.

### 3-4 operators working simultaneously



- **Mod. DS CD 125i** Code CD125i  
 This three-phase model is advised in the buildings with max. surface of about 3.500 m<sup>2</sup>. The frequency converter allows the adaptation at the kind of cleaning surface or at the number of operators. The model is compact and all the components (electric control panel included) allow a space reduction and a quick installation.

### 4 operatori in contemporanea



- **Mod. DS D02 100 I** Code D100ST  
**Mod. DS D02 125 I** Code D125ST  
 This three-phase model is advised in the buildings with max. surface of about 4.000 m<sup>2</sup>. This model can be enlarged to 6 operators working simultaneously. In this case the diameters of the tubes shall be suitable to allow more operators working simultaneously.

### 6 operators working simultaneously



- **Mod. DS F03 125 I** Cod. F125ST  
 This three-phase model is advised in the buildings with max. surface of about 6,000 m<sup>2</sup>.

### 8 operators working simultaneously



- **Mod. DS H02 125i** Cod. H125ST  
 This three-phase model is advised in the buildings with max. surface of about 8,000 m<sup>2</sup>. The model is for 8 operators working simultaneously, in this case also the diameters of the tubes shall be suitable to allow more operators working simultaneously.

### 8-9 operators working simultaneously



- **Mod. DS HK 175i** Cod. H175iCod. H125ST  
 This three-phase model is advised in the buildings with max. surface of about 9,000 m<sup>2</sup>. The frequency converter allows the adaptation at the kind of cleaning surface or at the number of operators is for 8-9 operators working simultaneously, in this case also the diameters of the tubes shall be suitable to allow more operators working simultaneously.

## Central vacuum systems

**Please notice:** in the case in which one need a central vacuum cleaner with more than 6 operators working simultaneously, we advise to install 2 or more independent systems.

### ! WARNING !

All the separators are equipped with a manual filter shaker device and they are arranged for the automatic filter shaking device installation which is advised in order to reduce the filter cleaning operations.

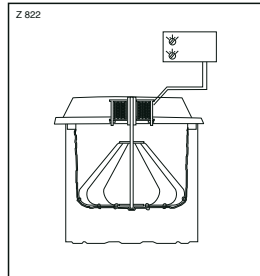

### List of optional for mod. DS Super Compact

- Filter self-cleaning device with circuit board. This device permits the automatic, daily cleaning of the filter, thereby always guaranteeing its full vacuum efficiency. Code IS91
- Double cyclone  
The upper cyclone protects the filter and brings the mixture flow air-dust by creating a first gravitational separation. The lower cyclone obstructs the lift of the dust
- Plastic bags for dust collection, 20-piece-package. Code ER628

For the installation, please see the instructions attached to each optional.

### List of optional for mod. DS Modular range

- Automatic self-cleaning filter device with electronic card.  
This device permits the automatic, daily cleaning of the filter, thereby always guaranteeing its full vacuum efficiency.  
mod. with separator 100 l code IS92  
mod. with separator 125 l code IS01
- Grill and pipe  
It allows the use of the plastic bags  
mod with separator 100 l code IS05  
mod with separator 125 l code IS07
- Plastic bags for dust collection, 20-piece-package.  
mod. with separator 100 l code IE601  
mod. with separator 125 l code IE602
- Cyclone  
It divides the filter chamber from the container by protecting the filter from the thicker dust.  
Mod. with separator 100 l code IS08

For the installation, please see the instructions attached to each optional.

### Technical data of the central units

| CENTRAL UNIT OF MOD. SUPER COMPACT |                   | Mod. DS Super Compact 1,5 single-phase | Mod. DS Super Compact Turbo 2,2 single-phase | Mod. DS Super Compact 2,2 three-phase | Mod. DS Super Compact Turbo 4,5i three-phase |
|------------------------------------|-------------------|--|--|---------------------------------------|--|
| Operators                          |                   | 1                                      | 2  | 1                                     | 2  |
| Motor power                        | kW                | 1,5                                    | 2,2@50Hz                                     | 2,2                                   | 4,5@50Hz                                     |
| Voltage requirement                | V                 | 230                                    | 230  | 380 - 400                             | 380 - 400                                    |
| Motor rotation                     | rpm               | 2880                                   | 2880 - 3480                                  | 2880                                  | 2170 - 5000                                  |
| Suction power max                  | mbar              | 300                                    | 320  | 320                                   | 360  |
|                                    | Inch H O          | 121"                                   | 128"   | 128"                                  | 144"   |
| Airflow max                        | m <sup>3</sup> /h | 251                                    | 306  | 320                                   | 520  |
|                                    | CFM               | 148                                    | 180  | 188                                   | 307  |
| Airflow                            | @ 140 mbar        | 180                                    | 244 - 285                                    | 270                                   | 150 - 450                                    |
|                                    | CFM@56"           | 106                                    | 143-168                                      | 159                                   | 88-265                                       |
| Airwatt                            | @ Ø32mm W         | 574                                    | 688  | 638                                   | 825  |
| Volume filter chamber              | l                 | 70                                     | 70   | 70                                    | 70   |
|                                    | gallons           | 18,5                                   | 18,5   | 18,5                                  | 18,5   |
| Dust receptacle capacity           | l                 | 40                                     | 40   | 40                                    | 40   |
|                                    | gallons           | 10,56                                  | 10,56  | 10,56                                 | 10,56  |
| Sound level                        | dB                | 65                                     | 68   | 67                                    | 68   |
| Filter surface                     | cm <sup>2</sup>   | 5.700                                  | 7.100  | 5.700                                 | 7.100  |
|                                    | sq. inch          | 884                                    | 1.100  | 884                                   | 1.100  |
| Weight with packaging/net          | kg                | 91 / 81,2                              | 94 / 84,2                                    | 98,8 / 89                             | 108 / 99                                     |
|                                    | pound             | 200/180                                | 207/185                                      | 200/180                               | 238/218                                      |
| Dimensions                         | LxPxA cm          | 54 x 40 x 161                          | 54 x 40 x 161                                | 54 x 40 x 161                         | 54 x 40 x 161                                |
|                                    | h x w x d inch    | 15.7x21.3x63.3"                        | 15.7x21.3x63.3"                              | 15.7x21.3x63.3"                       | 15.7x21.3x63.3"                              |

|                            | Mod.<br>DS A01<br>100L<br>Code<br>A100 | Mod.<br>DS A01<br>125L<br>Code<br>A125 | Mod.<br>DS B01<br>100L<br>Code<br>B100ST | Mod.<br>DS B01<br>125L<br>Code<br>B125ST | Mod.<br>DS B02<br>100L<br>Code<br>B200 | Mod.<br>DS B02<br>125L<br>Code<br>B225 | Mod.<br>DS BC<br>100i<br>Code<br>BC100i | Mod.<br>DS C03<br>100L<br>Code<br>C100 | Mod.<br>DS C03<br>125L<br>Code<br>C125 | Mod.<br>DS CD<br>125i<br>Code<br>CD125i | Mod.<br>DS D02<br>100L<br>Code<br>D100 | Mod.<br>DS D02<br>125L<br>Code<br>D125 | Mod.<br>DS EF<br>125i<br>Code<br>EF125i | Mod.<br>DS F03<br>125L<br>Code<br>F125ST | Mod.<br>DS H02<br>125L<br>Code<br>H125ST | Mod.<br>DS HK<br>175i<br>Code<br>HK125i |
|----------------------------|--|--|--|--|--|--|---|--|--|---|--|--|---|--|--|---|
| Operators                  | 1                                      | 1                                      | 2  | 2  | 2                                      | 2                                      | 2+1                                     | 3                                      | 3                                      | 3+1                                     | 4                                      | 4                                      | 5+1                                     | 6  | 8  | 8+1                                     |
| Max building surface *     | 1.000                                  | 1.000                                  | 2.000                                    | 2.000                                    | 2.000                                  | 2.000                                  | 2.500                                   | 3.000                                  | 3.000                                  | 3.500                                   | 4.000                                  | 4.000                                  | 5.500                                   | 6.000                                    | 8.000                                    | 9.000                                   |
| Nominal motor power        | 1x2,2                                  | 1x2,2                                  | 1x5,5                                    | 1x5,5                                    | 2x2,2                                  | 2x2,2                                  | 1x4,5                                   | 3x2,2                                  | 3x2,2                                  | 1x5,5                                   | 2x5,5                                  | 2x5,5                                  | 1x7,5                                   | 3x5,5                                    | 2x7,5                                    | 1x11                                    |
| Voltage requirement        | 380-400                                | 380-400                                | 380-400                                  | 380-400                                  | 380-400                                | 380-400                                | 380-400                                 | 380-400                                | 380-400                                | 380-400                                 | 380-400                                | 380-400                                | 380-400                                 | 380-400                                  | 380-400                                  | 380-400                                 |
| Inlets voltage requirement | 12                                     | 12                                     | 12                                       | 12                                       | 12                                     | 12                                     | 12                                      | 12                                     | 12                                     | 12                                      | 12                                     | 12                                     | 12                                      | 12                                       | 12                                       | 12                                      |
| Suction power              | 320                                    | 320                                    | 360                                      | 360                                      | 320                                    | 320                                    | 340                                     | 320                                    | 320                                    | 360                                     | 360                                    | 360                                    | 360                                     | 360                                      | 380                                      | 320                                     |
| Airflow max                | 316                                    | 316                                    | 552                                      | 552                                      | 632                                    | 632                                    | 690                                     | 942                                    | 942                                    | 868                                     | 1100                                   | 1100                                   | 1264                                    | 1640                                     | 1810                                     | 1490                                    |
| Airflow @140 mbar          | 224                                    | 224                                    | 407                                      | 407                                      | 440                                    | 440                                    | 165-565                                 | 655                                    | 655                                    | 223-784                                 | 805                                    | 805                                    | 840                                     | 1210                                     | 1470                                     | 1220                                    |
| Sound level                | 68                                     | 68                                     | 78                                       | 78                                       | 68                                     | 68                                     | 68                                      | 68                                     | 68                                     | 71                                      | 78                                     | 78                                     | 71                                      | 78                                       | 78                                       | 78                                      |
| Engine weight              | 51,5                                   | 51,5                                   | 156                                      | 156                                      | 106                                    | 106                                    | 65                                      | 157                                    | 157                                    | 163                                     | 325                                    | 325                                    | 185                                     | 486                                      | 369                                      | 195                                     |
| Engine width               | 47,5                                   | 47,5                                   | 59,5                                     | 59,5                                     | 47,5                                   | 47,5                                   | 53                                      | 47,5                                   | 47,5                                   | 67                                      | 59,5                                   | 59,5                                   | 59,5                                    | 59                                       | 59,5                                     | 70                                      |
| Engine depth               | 65                                     | 65                                     | 96                                       | 96                                       | 65                                     | 65                                     | 63,5                                    | 65                                     | 65                                     | 97                                      | 96                                     | 96                                     | 96                                      | 96                                       | 97                                       | 67                                      |
| Engine height              | 50                                     | 50                                     | 65                                       | 65                                       | 97                                     | 97                                     | 58                                      | 97                                     | 97                                     | 65                                      | 125                                    | 125                                    | 65                                      | 185                                      | 145                                      | 97                                      |
| Filter chamber capacity    | 160                                    | 210                                    | 160                                      | 210                                      | 160                                    | 210                                    | 160                                     | 160                                    | 210                                    | 210                                     | 160                                    | 210                                    | 210                                     | 210                                      | 210                                      | 580                                     |
| Dirt receptacle capacity   | 100                                    | 125                                    | 100                                      | 125                                      | 100                                    | 125                                    | 100                                     | 100                                    | 125                                    | 125                                     | 100                                    | 125                                    | 125                                     | 125                                      | 125                                      | 175                                     |
| Filter surface             | 16.500                                 | 35.000                                 | 16.500                                   | 35.000                                   | 16.500                                 | 35.000                                 | 16.500                                  | 16.500                                 | 35.000                                 | 35.000                                  | 16.500                                 | 35.000                                 | 35.000                                  | 35.000                                   | 35.000                                   | 62.000                                  |
| Separator weight           | 57                                     | 95                                     | 57                                       | 95                                       | 57                                     | 95                                     | 57                                      | 57                                     | 95                                     | 95                                      | 57                                     | 95                                     | 95                                      | 95                                       | 95                                       | 200                                     |
| Separator width            | 65                                     | 80                                     | 65                                       | 80                                       | 65                                     | 80                                     | 65                                      | 65                                     | 80                                     | 80                                      | 65                                     | 80                                     | 80                                      | 80                                       | 80                                       | 88                                      |
| Separator depth            | 63                                     | 72                                     | 63                                       | 72                                       | 63                                     | 72                                     | 63                                      | 63                                     | 72                                     | 72                                      | 63                                     | 72                                     | 72                                      | 72                                       | 72                                       | 95                                      |
| Separator height           | 153                                    | 157                                    | 153                                      | 157                                      | 153                                    | 157                                    | 153                                     | 153                                    | 157                                    | 157                                     | 153                                    | 157                                    | 157                                     | 157                                      | 157                                      | 210                                     |

\* Approximate values

## MAKING OF THE PIPING

### General instructions

- The tubing should be installed together with or after the plumbing system in order to avoid changing of the route. The latter should be short and as much as possible.
- Unlike the plumbing system, the tubes of the suction system do not need any slopes.
- If obstacles are found, route and slope can be changed.
- The points of connection of the vertical column and of the breather pipe to the central vacuum cleaner are indicated in the paragraph "Location of the central vacuum cleaner", on page 5.

### Laying of the tubing

The non-observance of the following instructions causes clogging, a reduction in the air flow speed and annoying whistling.

#### How to cut the pipes

Pipes must be cut using the pipe-cutter fitting this purpose (e.g. the Disan pipe-cutter code GE801 for diameters of 63 mm and pipe-cutter code GE803 for diameters up to 100 mm).

Then eliminate the slight defects inside the tube with a little knife or with glass-paper.

*Cutting the tubes with the hacksaw causes irregular cuts and slight defects, which cause clogging.*

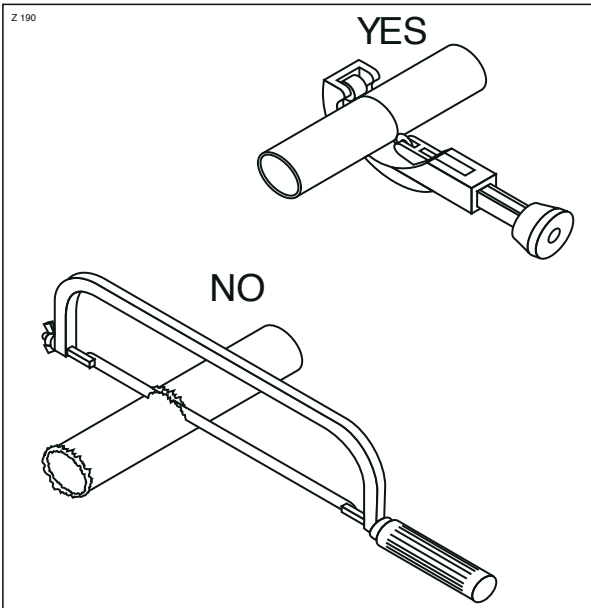

### Consider the air-flow

When you install the joints, follow the direction of the air-flow.

*The joints installed and positioned in the opposite direction of the air-flow cause clogging and the slowing down of the flow itself.*

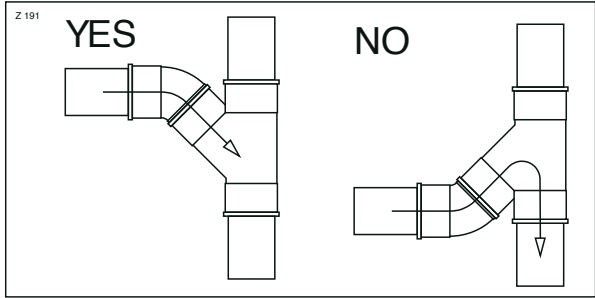

### Insert a secondary line into the main one

Mount the special reducers after the sweep TY, if needed.

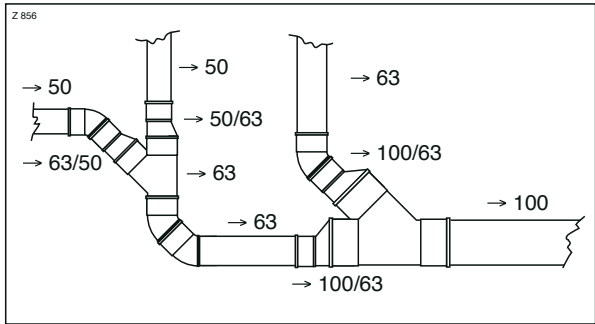

If a secondary line is installed from the bottom to the top, it must be inserted into the main tube on a side or from above.

*If a secondary line is installed from the bottom to the top and is inserted into the main tube from the bottom, the dust that flows in the tubes falls and deposits inside the inlet valve.*

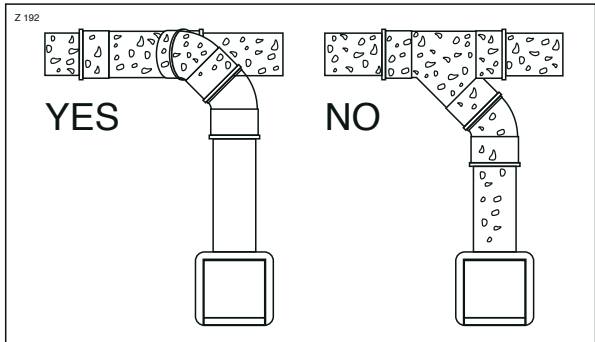

## Central vacuum systems

### How to glue the tubes

Tubes and fittings have to be glued exclusively head to head.

*Tubes which are not glued head to head or which are improperly cut cause clogging.*

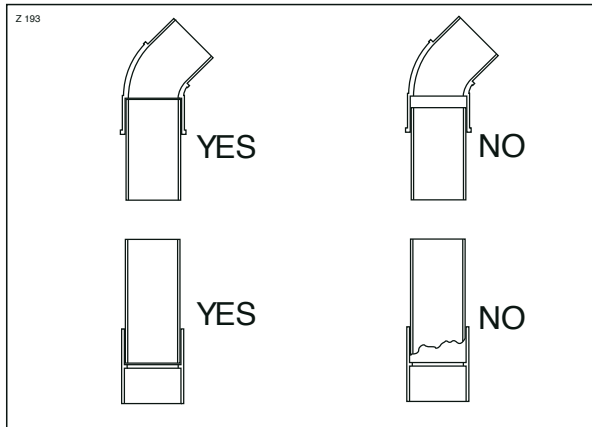

Tubes and fittings are glued using a special adhesive (cold gluing). The adhesive must be exclusively put on the “tongue” connectors/tubes.

*If the adhesive is put on the “groove” connectors, this causes filaments inside the tube.*

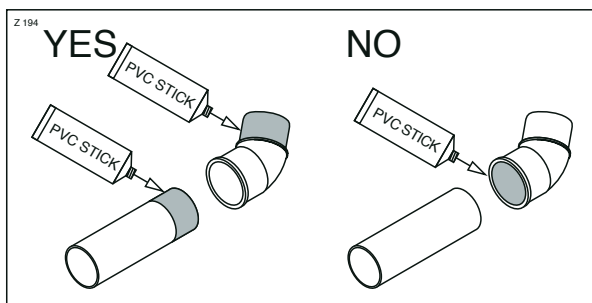

**Please notice:** when laying several fittings, we recommend - before gluing - to mark with a felt-tip pen the exact point (grading) where the fittings have to be connected. **IMPORTANT!** The adhesive reacts very quickly (approx. 20 seconds) after which it is impossible to move the glued fittings.

### ! WARNING !

Do not install external piping in contact with sunbeams and atmospheric agents. In these cases we advise to use zinc-coated stainless steel tubes. Contact the technical office Disan.

If it is not possible to avoid the installation of external tubes, cover the tube with thermal insulating material (normally used in the hydraulic field).

### Laying and connection of the water vacuum system

- Insert tight the rubber couplings of the flexible tubes (connected to the water pick-up):
  1. to the pipe fitting equipped to connect to the main line of the system.
  2. to the pipe fittings equipped to connect to the line coming from the inlet valves for water suction
- Please pay attention that the water exhaust valve will be exactly positioned up to the runner cup in order to permit the perfect convey of the vacuumed liquids in the pipe.

**Please notice:** the rubber couplings could be inserted directly in the piping diameter 63 mm or with the reducers of the other diameters.

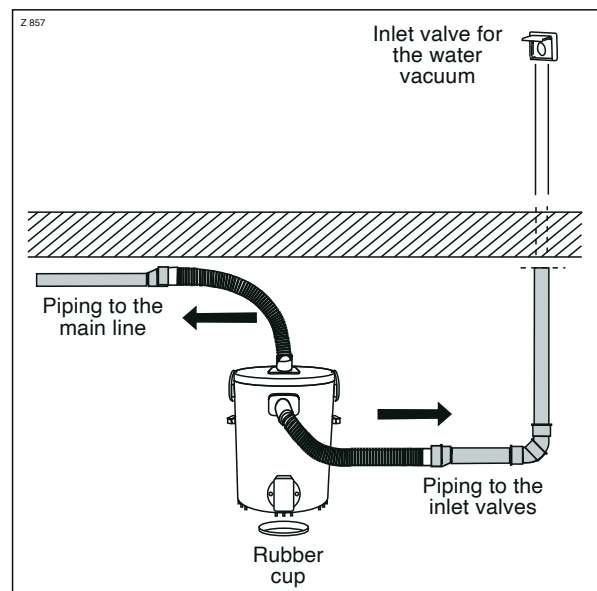

## Central vacuum systems

### Laying of the backup boxes

The backup boxes must be installed flush with the plaster and it must be positioned perfectly in an horizontal position.

The chases on the wall change according to the inlet socket that one intends to install:

- *Disan* rectangular backup box code SD101/SD102  
 minimal depth (p) = 70 mm  
 minimal width (l) = 125 mm  
 minimal height (h) = 125 mm
- *Disan* square inlet valve code SD501/SD502  
 minimal depth (p) = 65 mm  
 minimal width (l) = 85 mm  
 minimal height (h) = 140 mm

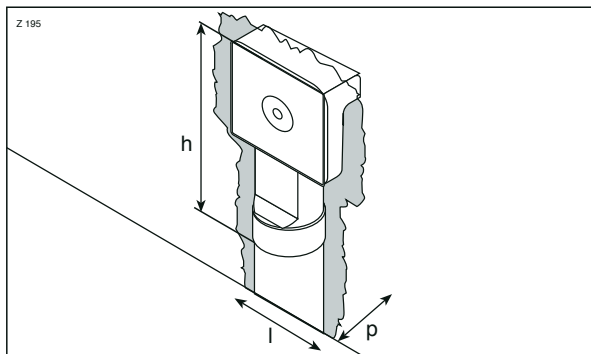

### Installation scheme of the backup box with 90° ell.

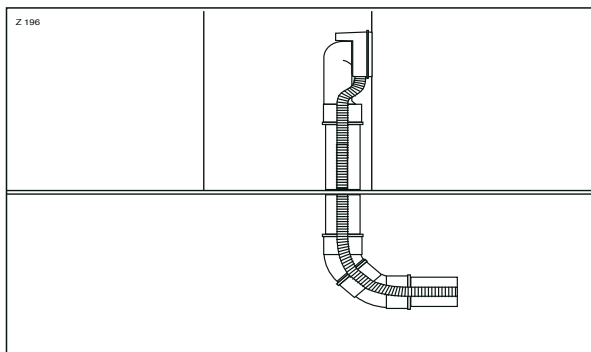

### Installation scheme of the backup box with straight fitting.

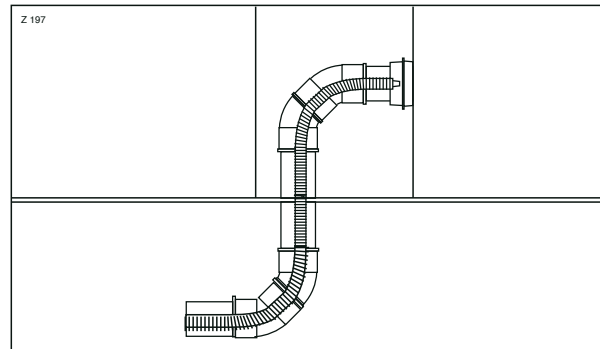

### Application only on the movable boards (panel wall)

Use the proper square backup boxes for inlet valves Olympia, Royal and Majestic.

Depending on the panel thickness fix the box of the backup box with its screws.

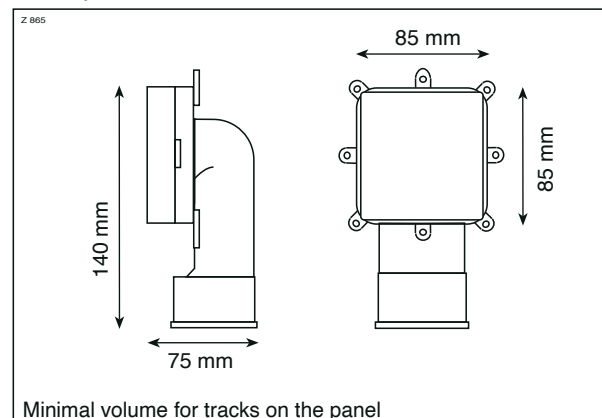

## INSTALLATION OF THE BREATHER LINE

### Installing the breather line towards the outside

Mount the silencer at the furthest point of the line in order to absorb as much noises as possible (see paragraph "Planning of the breather pipe" on page 8).

It is not advised to use too many sweep ells which could slow down the expulsion and consequently reduce the motor performances.

It is advised that the last meters (max. 5 m) of the breather line have a piping with a larger Ø in comparison with those of the pipes used for the vertical column. (see pages 8-9).

### LAYING OF THE ELECTRIC CONTROL LINE

The electric control line is installed in the following way:

the electric cable coming out from the electrical junction box, which is placed near the central unit, is installed together with the tubing and is connected from one backup box to the other.

Fix the sheath to the tubes using the suitable wire clamps.

The backup boxes are connected by inserting the ends of the electric sheath pre-inserted into the two openings of the backup box.

**Please notice:** in order to allow future connection to the binding screw and to the inlet valve insert the electric cables for approx. 5 cm into the backup box and in the electric junction box.

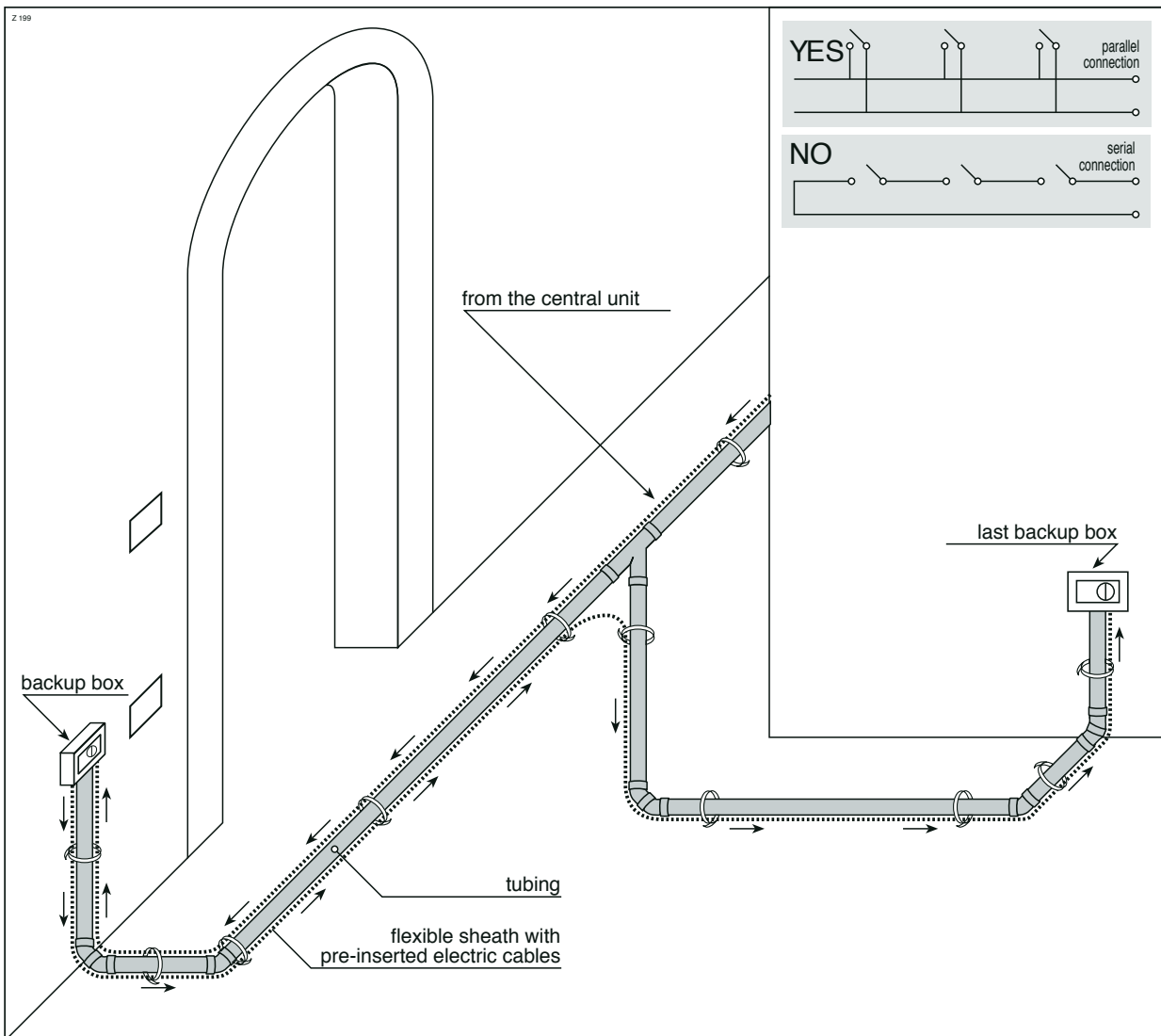



**TESTING**

Testing occurs after completing the laying of the tubes and before laying the floor.

The purpose of the tests is in order to guarantee that the tubes are not damaged and that everything has been properly glued. Otherwise the system may not be air-tight.

This is very important because:

- even the smallest air infiltration into the tubing causes a reduction in depression values and airlosses;
- after the laying of the floors, it is very expensive to solve these problems.

**Please notice:** while laying the floors and plasters, be careful not to damage the pipe line.

**1. Get the vacuum cleaner tester *Disan* (code GE815).**

*Disan's* testing kit includes the vacuum cleaner and all the fittings necessary for connection to the pipe line. If you use a traditional vacuum cleaner, ensure a perfect tightness using rubber couplings or similar devices.

*Disan's* testing-kit is composed of:

- 1 powerful vacuum cleaner equipped with a pre-mounted inlet valve.
- 1 vacuum gauge
- 1 stethoscope
- 3 PVC reducers 100-50 mm/80-50 mm/63-50 mm adapters

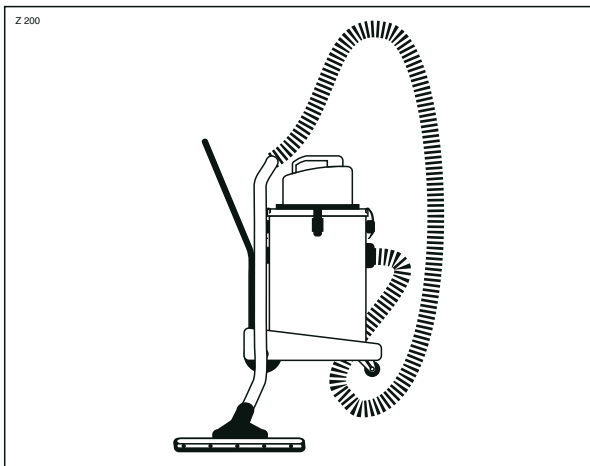

**2. Measure the depression produced by the vacuum cleaner**

Depression is measured by introducing the corresponding vacuum gauge (code GE800) into the end of the hose of the testing vacuum cleaner.

While the machine is working, read the depression value on the vacuum gauge.

**Please notice:** we suggest to measure the depression at every test, because it can change from site to site due to the different voltage.

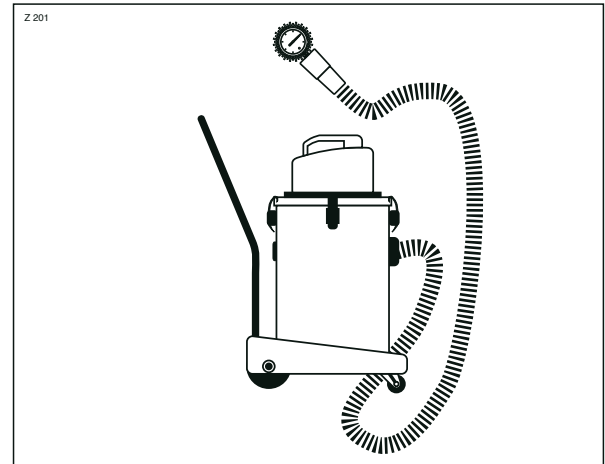

**3. Insert the hose fitting into the end of the pipe line by using the most suitable fitting.**

The end of the pipe line is the point where the central vacuum cleaner has to be connected.

**Please notice:**

- the vacuum cleaner must be connected to the pipe line so that there won't be any possibility to have reduction of the depression value and airlosses.
- *Disan's* vacuum cleaner tester is equipped with a thermostat which automatically switches off if the motor gets overheated. After cooling(8-10 minutes) the vacuum cleaner switches on again automatically.

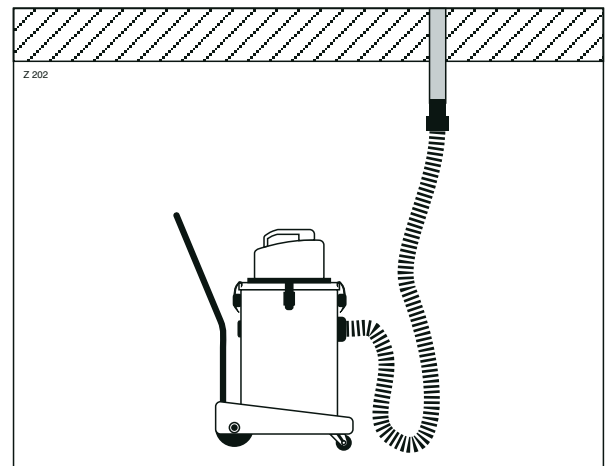

### 4. Check the closing caps in the backup boxes

In order to carry out this part of the testing successfully, you need to make sure that all the 90° bends of the backup boxes are provided with the taps for the airtight closure of the system.

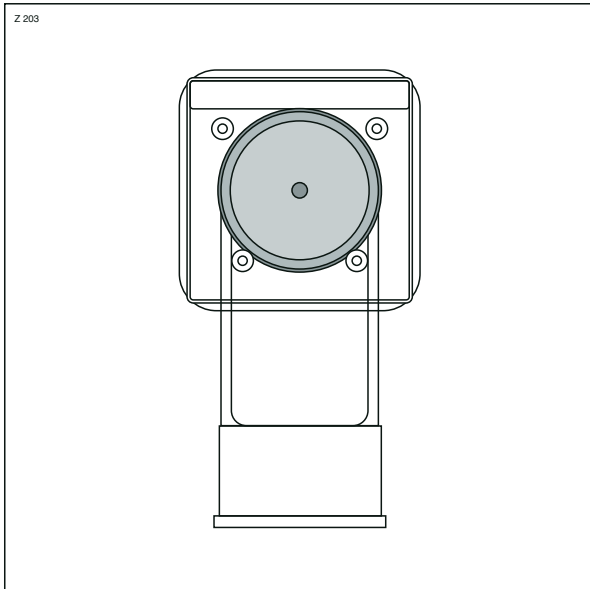

### 5. Insertion of the vacuum gauge

Insert the vacuum gauge directly into the inlet socket mounted on the vacuum cleaner.

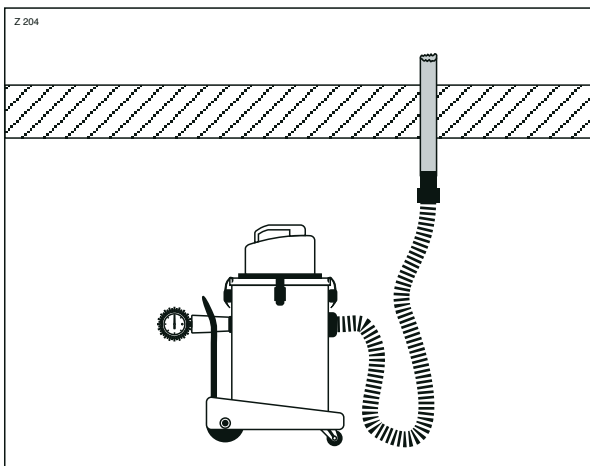

### 6. Switch on the testing vacuum cleaner

Wait a few seconds so that the system creates the depression needed for the measurement. The vacuum gauge will indicate the exact depression value once the pointer has come to a standstill.

### 7. Measure the depression at the inlet valve

Check that the depression value measured at the inlet valve corresponds with that at the inlet of the testing vacuum cleaner. If the tubes and the fittings have been glued in a perfect way, the values will coincide.

**Please notice:** if the measured values do not correspond, there is an air infiltration in the tubing.

### Location of losses

#### 1. Locating the origin of the whistles

Follow systematically the pipe line and check if it is damaged. At the same time, listen if there are any whistles. If this check does not provide any successful result, use the stethoscope (part of *Disan's* testing kit) to listen systematically along the tubing for whistles; in particular where fittings and tubes have been glued. Even the minimum loss produces irritating noises!

#### 2. Repair the tubing

If necessary, replace the tube or the fittings so that the tubing is perfectly tight.

Repeat the testing of the system.

After carrying out the test successfully, *Disan* suggests giving to the purchaser or to the chief of works a copy of the certificate (see second-last page of this handbook) and of the tubing distribution in order to avoid disputes or future liabilities.

### INSTALLATION AND CONNECTION OF THE INLET VALVES AND OF THE CENTRAL VACUUM CLEANER

#### Installation and connection of the inlet valves

Remove the protection cap and the cover of the backup box

Connect the inlet valves to the power mains

The two incoming electric cables must be connected in parallel to the two outgoing cables with a binding screw. Then connect the binding screw to the inlet valve.

#### Resistances

If you use the sequential starting device please control if there is a resistance (code IS106) 4700Ω on every single inlet valve. The resistances can be installed later and welded on one of each outgoing cable of the control operation panel which is on the inlet valve. Protect the resistance with a thermoproof covering.

#### Install the inlet valves

- Put some soap on the corresponding tightness O.R. for an easier insertion of the inlet valve into the backup box.

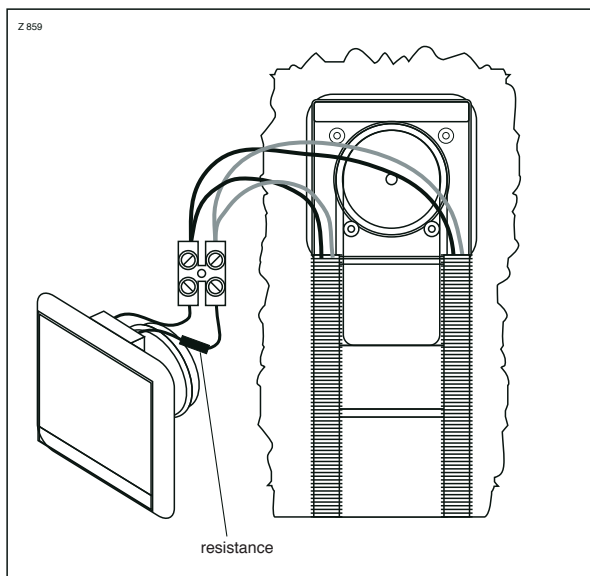

- Use the proper extensions if the backup box is too embedded with respect to the plaster's surface (for instance because of the panelling of the walls). If necessary, it is possible to glue several extensions.

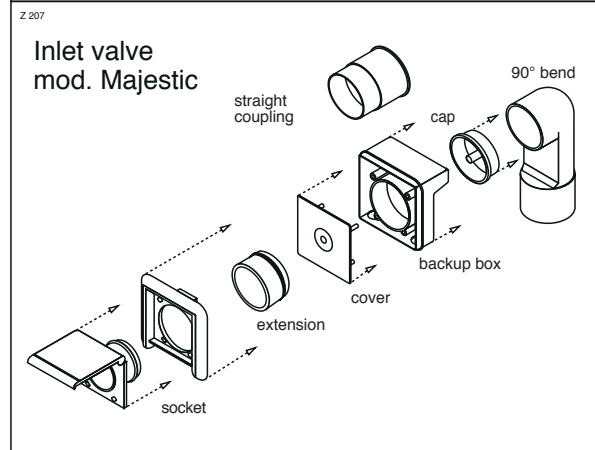
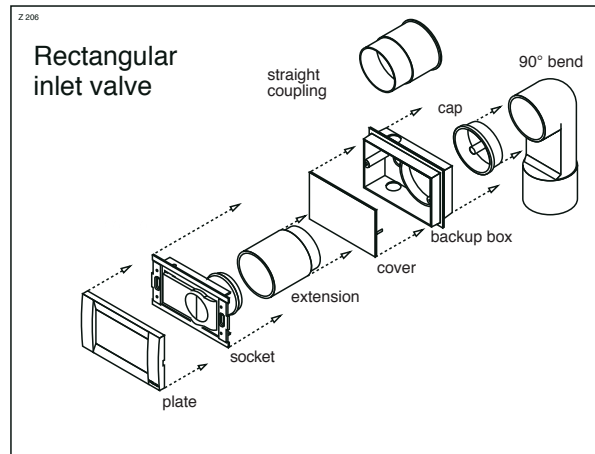

- Pre-screw carefully the screws of the inlet valve with a screwier, so that the socket is not deformed.
- Adjust the position of the inlet valve with a screwdriver, using washers if necessary.

**Please notice:** if the screws are not properly screwed this may compromise the perfect tightness of the inlet valve and as a consequence the performance of the system.

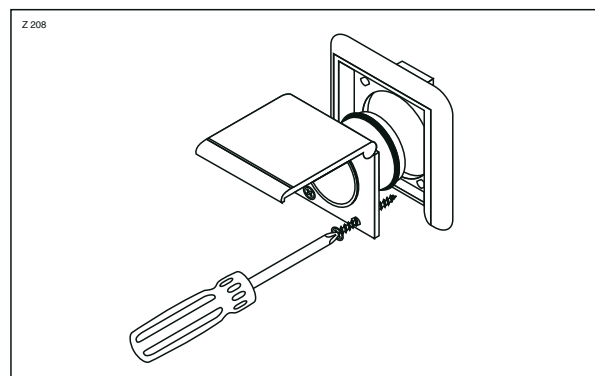

## Central vacuum systems

### Installation and connection of the central vacuum cleaner

#### Features of the electric power supply:

Be sure the section(diameter) of electric cables is at least 2,5 mm<sup>2</sup>.

#### • Mod. DS Super Compact

In the dust container of the central unit the following parts are contained:

- 2 collars
- 1 tube Air for the connection to the vacuum piping

The central unit can be installed on the wall or on the floor.

When it is installed on the wall with the special optional bracket for wall fixing (code IS90) please take into account the minimal distances requested (as in the drawing), in order to allow the reaching of the dust container. Please see the instructions in the mounting kit.

#### Stages for the connection of the central unit:

1. connect the tube Air 1 to the vacuum tube 2 which is located on the back side of the central unit and to the vacuum piping to the inlet valves 3, fixing with a collar for the sealed connection 4 on both sides.
2. if you want to install a breather pipe remove the breather protecting screen 5 from the double lock tube 6 by taking out the two lateral rivets 7. With the optional rubber hose (code TE920) connect the zinc tube 6 to the breather piping , by fixing them with the help of 2 collars 4 on both sides.
3. remove the plug of the sockets 10 which is located on the socket 111 and connect to the power main 12 V by paying attention to do the connection on the grips 1 and 2 of the plug. Reconnect the plug to the socket.
4. connect the plug 13 to an electricity socket 14 and the tension should be the same of that written on the identification plate 15.

**Please notice:** the model DS Super Compact Turbo 4,5i needs the use of a differential circuit breaker switch FI of the value of 300 mA.

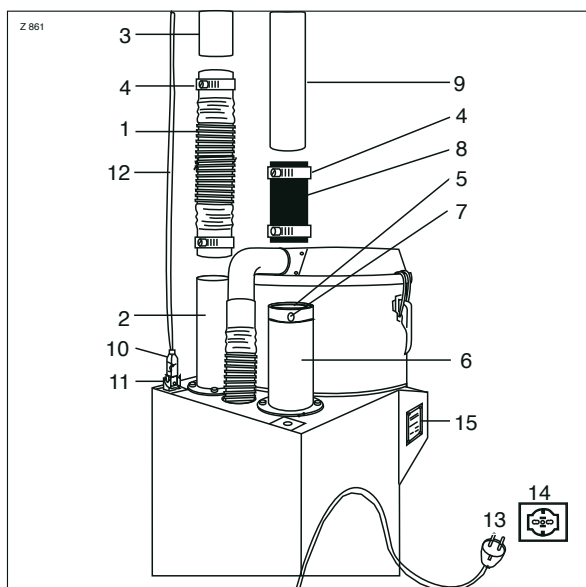

## Central vacuum systems

### Steps for the dismantling of the central unit

For the installation of some optional and for maintenance reasons it is necessary to dismantle firstly the central unit as described in the following stages.

1. unscrew the hose clamp 1 which connects motor-silencer.

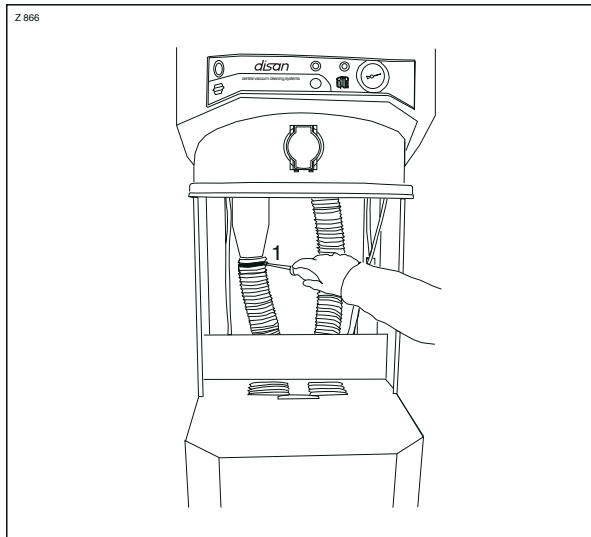

2. take off the rubber hose 2 of the flexible hose from the zinc sweep ell of the cover and take it out

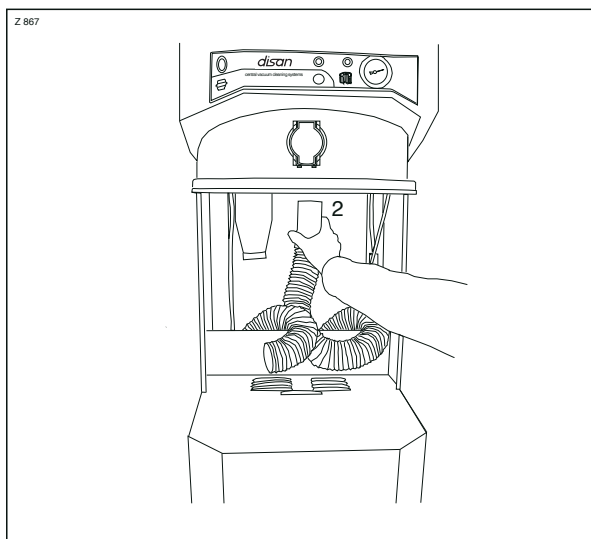

3. remove the supply 3 from the control panel

4. remove the transparent depression tube vacuum gauge 4 from its connection placed on the motor

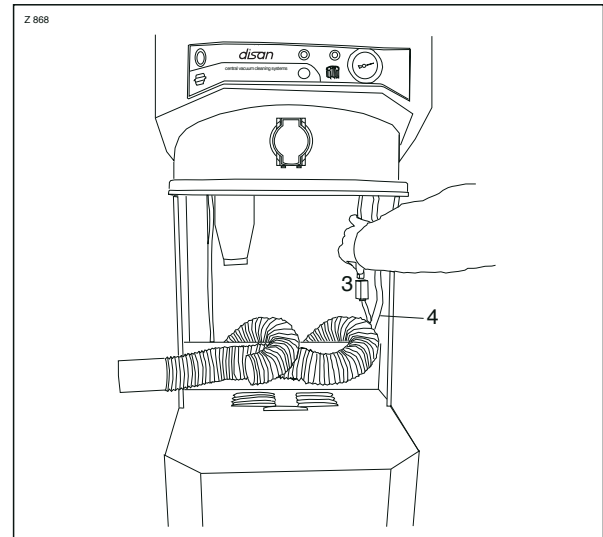

5. dismantle the main switch 5 from the supporting frame covering 6

6. unscrew the screws 7 of the supporting frame covering 4 from the supporting frame 8

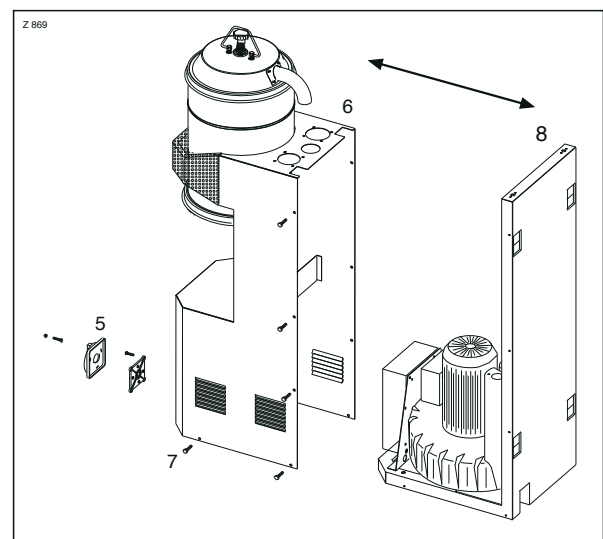

7. separate the covering supporting frame 8

After these operation reassemble the central unit by following the steps backwards.

# Central vacuum systems

## • Mod. DS Super Compact

In the dust container of the central unit the following parts are contained:

- 1 rubber hose for the connection to the breather pipe.
- 4 collars
- 1 tube Air for the connection of the vacuum piping.

We advise to locate the vacuum motors on the left side of the dust separator. If differently, please contact the technical office Disan.

Fix on the wall, near the central unit, the electric box and, if present, the switchboard of the automatic filter cleaner and the electric division box for 12V remote control wire.

Steps for the connection of the central unit:

1. connect the tube Air 1 to the vacuum hose 2 of the motor and to the zinc-coated junction 3 of the cover of the dust separator.

2. connect the zinc-coated junction 4 on the filter chamber of the dust separator to the inlet valves 5 with the rubber hose 6 and fix it with two collars 7 on both sides.

3. with the help of the rubber hose 8, connect the rubber connection 9 of the motor to the breather piping 10 by fixing it with two collars on both sides.

4. connect the electric cables 12 of the motor and the electric power 12 V to the inlet valves 13 to the main electric board 14. Connect also the electrical boards of the automatic filter shaking and the electric division box 12 V remote control wire (optional). The schemes of the electric distribution of the boxes can be find into its electric box. For the models DS BC 100i and CD 125i its electric panels are integrated in the machine.

5. connect the mains cable 15 to a control panel 16 with 380-400 Volt tension.

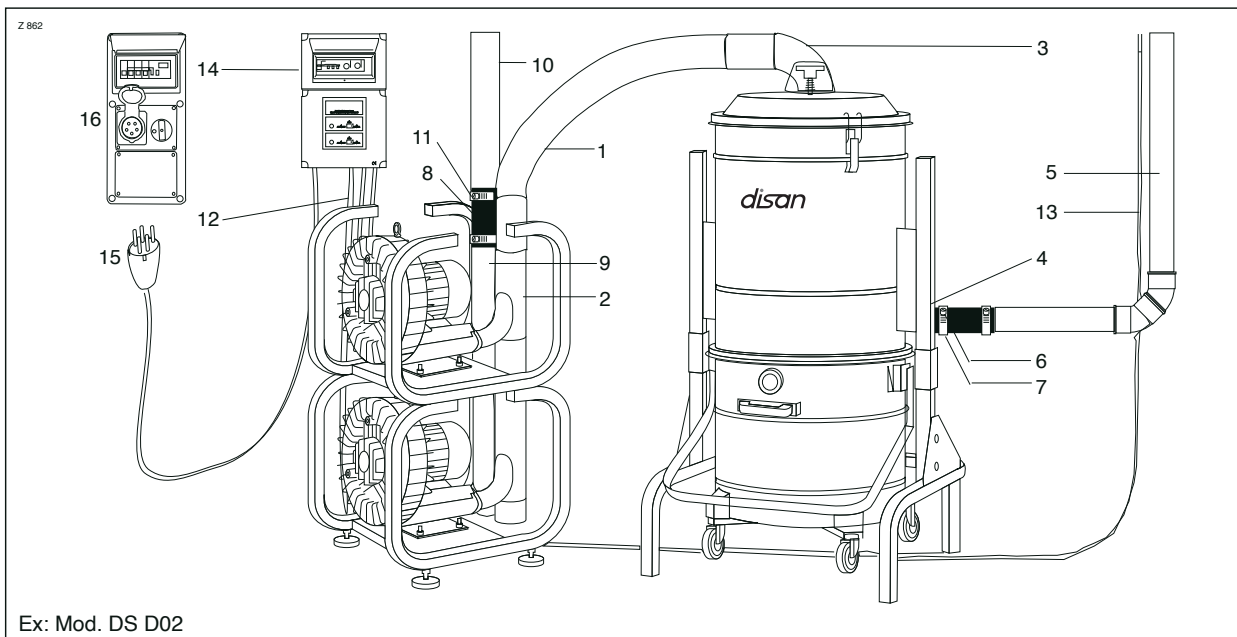

## Electronic control sequential starting device

The models equipped with an electronic control sequential starting device are predisposed in the production stage. If there would be any troubleshooting please contact the technical office *Disan*.

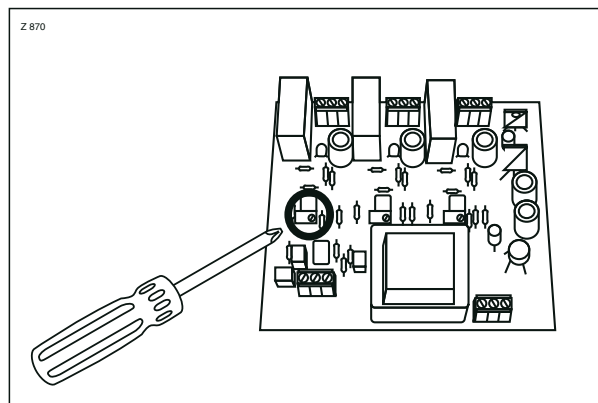

### Check of the functioning of the by-pass valve on the dust separator

Every dust separator is equipped with a by-pass valve for the vacuum of air which acts when in the piping there is too much suction power.

- On the systems with 2,2 kW motors the by-pass valve on the dust separator should be always closed.
- The by-pass valve is used only on the systems with 5,5 kW motors, when on a motor just one operator is working. The excess of vacuum power is compensated by the by-pass valve. Check that the valve is open and adjust eventually the bolt for a maximal efficiency.

#### Steps for the adjustment of the by-pass valve

1. with a wrench unscrew the bolt of the cover 1 and remove the metal cover and remove the soundproof cover 2.

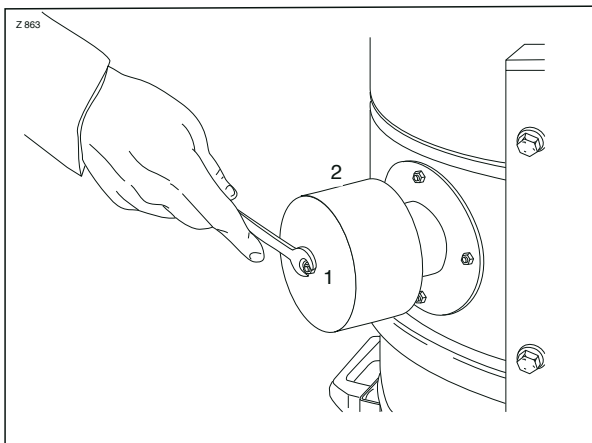

2. start the system by inserting the 2 flexible hoses into the inlet valves and vacuum by both of them.
3. adjust with a wrench the by-pass valve 3, by opening it until when an air infiltration could be heard

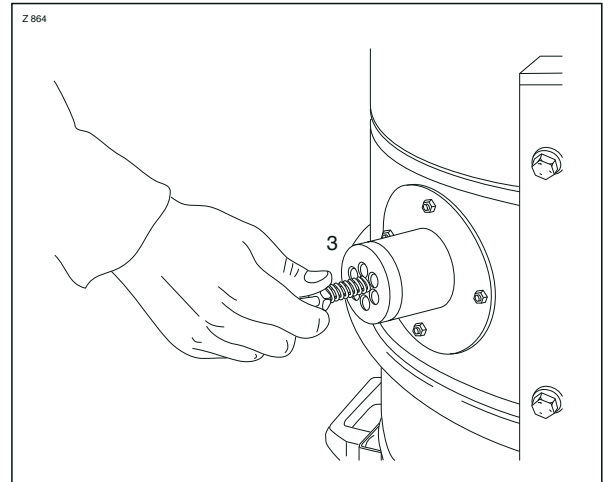

4. remove one flexible hose from the inlet valve and check that the inlet valve starts working again
5. close the valve to the closing
6. reassemble the soundproof cover

### By-pass valves adjustment

In the case that in the piping some by-pass valves will be installed for the self-cleaning of the lines, close the valve on the dust separator and adjust such valves as described in the paragraph "Check of the functioning of the by-pass valve on the dust separator".

#### Steps for the adjustment

1. After having removed the soundproof cover of the valve, start the system by inserting 2 flexible hoses into the inlet valves.
2. Adjust the valve as described in the paragraph: "Check of the functioning of the by-pass valve on the dust separator".

# Central vacuum systems

## Testing of the inlet valves

### Testing the inlet valves

- Start the central vacuum cleaner up by inserting the vacuum gauge into whatever inlet valve of the system.

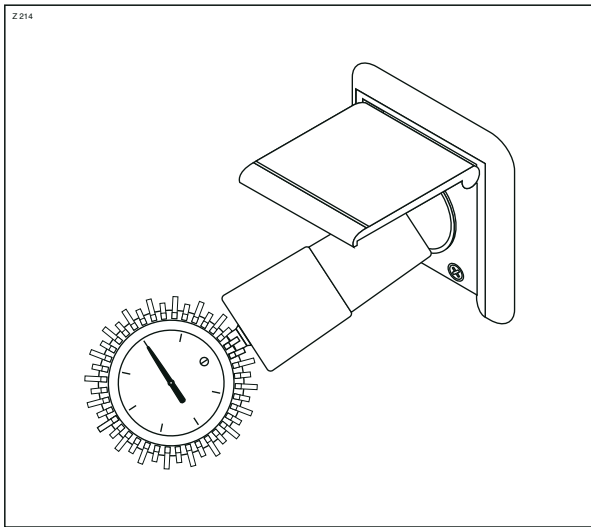

- Listen if there are any whistles due to losses of the inlet valves.

Whistles are due to:

1. an excessive screwing of the inlet valve into the backup boxes (see paragraph "Mounting and connection of the inlet valves")
2. a damaged or incorrect mounting of the gasket. Check if it is positioned correctly.

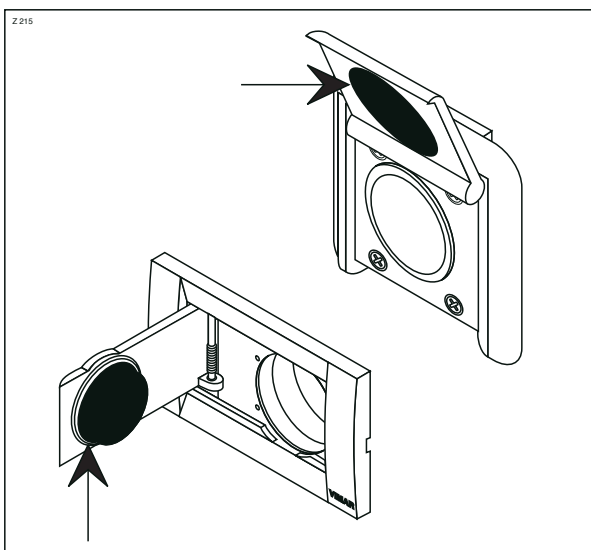

In case you notice whistles which aren't caused by the inlet valves, locate the origin of those whistles by placing the stethoscope on the wall or on the floor along the tubing.

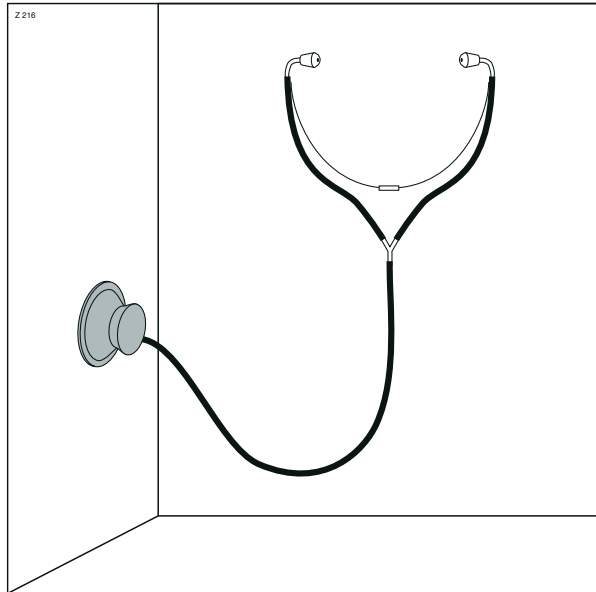

After repairing, measure the depression again.

## Final testing of the system

In this phase the installer tests the finished system.

**Start the vacuum cleaner up by inserting the vacuum gauge into whatever inlet valve and measure the depression.**

**Please notice:** if you use inlet valves with pin-jacks, the system can be started up creating a bridge with the two 12 V electric cables coming out of the central unit.

Wait a few seconds so that the system creates the depression necessary for the measurement. When the pointer has come to a standstill, read the exact value of depression.

**Then check that the depression measured at the inlet valve corresponds with that measured at the inlet of the central vacuum cleaner.**

These measures must correspond. Small differences in the value indicated in the "Technical data" sheet can derive from the voltage of the electric system and could be considered in the normal tolerance range. If the two values do not correspond, there is an air-infiltration in the tubing. Locate the origin of the loss by putting the stethoscope on the wall or on the floor along the tubing. An infiltration is present where you locate a whistle.

## Delivery of the finished system to the customer

### Practical testing of the functioning of the system

It is preferable that the customer himself cleans in order to check whether the suction system works perfectly.







# Certification

The installing company

---

confirms the **TESTING** of the tubing in compliance with Disan's instructions.

Furthermore, it has been ascertained that:

1. no whistles are emitted by the tubing due to air-infiltrations
2. the depression measured at one inlet valve of the vacuum cleaning system corresponds with that measured at the testing vacuum cleaner.

Therefore any future damage is exclusively due to the intervention of a third party.

The installing company

Date \_\_\_\_\_

Attachment: tubing distribution plan

