



disan[®]

Central vacuum systems

**OPERATION AND MAINTENANCE
FOR CENTRAL VACUUM CLEANERS
MODEL: DS SUPER COMPACT**



**DS SUPER COMPACT 1,5
DS SUPER COMPACT 2,2
DS SUPER COMPACT 4,5 TURBO**

(c) Copyright by DISAN S.r.l.

Technical drawings and layout: Pallaoro Graphics

Any unauthorized reproduction, even partial, is forbidden.

Photos, drawings and descriptions in this handbook reflect the state of the art at the moment when this catalogue was printed. The company Disan reserves the right to update its production, previous catalogues and handbooks. For further information, please contact "DISAN"'s technical office.

Disan acknowledges a 1 year guarantee for parts having manufacturing defects. The guarantee is valid only if the instructions set out in this handbook are fully complied with.

CONTENTS

Introduction	4
Quality check	5
Unloading and handling of the equipment	5
Technical features and main parts	6
Central vacuum cleaner model DS Super Compact 1,5 – for one operator.....	6
Central vacuum cleaner model DS Super Compact 2,2 – for one operator.....	6
Central vacuum cleaner model DS Super Compact 4,5 Turbo – for two operators	6
Main parts.....	7
Optionals	7
Installation of the central vacuum cleaner	8
Ordinary maintenance (by the person in charge of the central vacuum cleaner)	8
Periodic filter cleaning	8
Emptying the dust container.....	9
Check of the automatic filter shaking device.....	10
Check of the turbine	10
Extraordinary maintenance	10
Filter control and replacement.....	10
Tables for brushes and spare parts.....	11
Inlet socket on the central vacuum cleaner	12
Safety instructions	12
Troubleshooting your central vacuum system	13
Identification data	15
Check list for the installer	15
Yearly maintenance contract	15
Layout DS Super Compact 1,5 and 2,2 models	16
Spare parts for the DS Super Compact 1,5 and 2,2 models	17
Layout DS Super Compact 4,5 Turbo model	18
Spare parts for the DS Super Compact 4,5 Turbo model	19
Certificate and guarantee terms	20

INTRODUCTION

Dear Client,

Thank you for trusting and choosing our brand. We are confident that the use of this DS SUPER COMPACT central vacuum system will fully satisfy you.

This product's details have been carefully designed so as to make it durable and always fully efficient.



• System quality

The components of the central vacuum cleaner have been manufactured in full compliance with EU directives on the safety of electrical systems. Disan's central vacuum cleaner was engineered for professional use, particularly focusing on the following elements:

1. solidity;
2. suction power;
3. long life with minimum maintenance;
4. safety of the low voltage electric system;
5. technologic quality;
6. minimum dimensions.

• Purpose of these instructions

The use of the central vacuum cleaning system is very simple and does not require specific technical knowledge. Nevertheless, a number of instructions have to be carefully followed in order to avoid any inconvenience during operation.

The purpose of this handbook is to convey to operators the fundamental criteria for the operation of the system. A table of failures at the end of this handbook helps troubleshoot the causes of malfunctions, if any.

Please treat this handbook with care and keep it for future reference.

• Choice of the person in charge of the system

We suggest appointing a "person in charge of the vacuum cleaning system", who attends to the emptying of the dust canister and to the maintenance of the system, who teaches cleaners how to use the system and who serves as an interlocutor with the technical assistance (to be provided by the installer).

• Lost handbook

If you lose or damage this handbook, ask the installer for another copy.

• State of the art and updates of this handbook

This handbook reflects the state of the art at the moment when it was printed.

The manufacturer reserves the right to update its products and the corresponding handbooks.

QUALITY CHECK

• Checks during production

Disan's central vacuum cleaners and their components are repeatedly subjected to quality and functional checks by highly qualified technicians during their manufacturing, in order to guarantee a long operation life and perfect operation for professional use. In this way it is guaranteed that Disan's products leave the manufacturing department in perfect conditions.

• Checks on delivery (control by the client)

All the material shipped was carefully controlled

before its delivery to the forwarder.

It is the purchaser's responsibility to always control the goods on delivery and check that they were not damaged during their transport. If a damage is found, accept the goods with reservation, specifying your observations on the delivery note. In case of damage of the material, immediately inform the carrier for subsequent damage compensation.

• Check of the finished system

The installer checks the system and performs a series of functional checks during its installation.

UNLOADING AND HANDLING OF THE EQUIPMENT

This handbook is attached to the packaging in such a way as to be clearly visible.

• Transport liability

The goods always travel at the client's risk to the place of destination and installation.

• Indications on handling

Lift the pallet carefully using the lift truck fitting this purpose.

Since the model DS SUPER COMPACT is particularly tall, check the stability and balanced positioning of the load on the forks. When moving, keep the load as low as possible for more stability and visibility, then operate with the maximum caution.

• Dimensions of the central vacuum cleaner

The central vacuum cleaner package is mounted on pallets designed for this purpose and shrink-wrapped. The following calculation of sizes and weights includes packaging. Measures are in centimetres.

Z.800

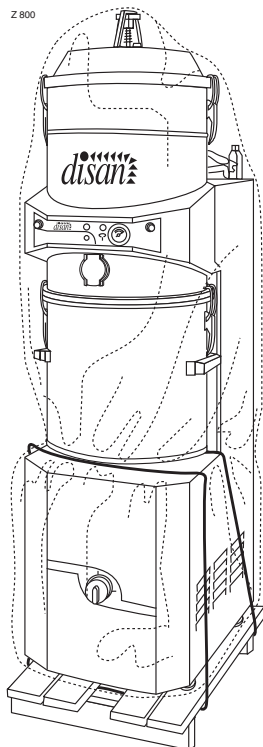

	DS SUPER COMPACT 1,5 MODEL	DS SUPER COMPACT 2,2 MODEL	DS SUPER COMPACT 4,5 TURBO MODEL
Height	172	172	172
Width	47	47	47
Depth	65	65	65
Weight in kg	82	87	91
	Model with automatic filter shaking device	Model with automatic filter shaking device	Model with automatic filter shaking device
Height	165	165	165
Width	47	47	47
Depth	65	65	65
Weight in kg	84	89	93

TECHNICAL FEATURES AND MAIN PARTS

Central vacuum cleaner model DS Super Compact 1,5 single phase, for one operator Code 6405



Central vacuum cleaner in sheet metal housing painted in epoxy powder with single phase lateral turbine channel, without transmissions and with approved magneto thermal motor safety switch, filter chamber, removable dust container, silencer, control panel, circuit board with 12 Volt inlets control and vacuum gauge, manual filter shaking device, filter made out of special cloth, with large surface and high filtering capacity, inlet socket with contacts.

motor power	kW	1.5
	HP	2
depression	mbar	300
airflow	m ³ /h	231
supply voltage	V	220-240
socket voltage	V	12
capacity of dust container	lit	38
filter surface	cm ²	5,700
weight	kg	76
noisiness	dB	65
height of vacuum cleaner	cm	161
width of vacuum cleaner	cm	40
depth of vacuum cleaner	cm	54

Central vacuum cleaner model DS Super Compact 2,2 three phase, for one operator Code 6406



Central vacuum cleaner in sheet metal housing painted in epoxy powder with three phase lateral turbine channel, without transmissions and with approved magneto thermal motor safety switch, filter chamber, removable dust container, silencer, control panel, circuit board with 12 Volt inlets control and vacuum gauge, manual filter shaking device, filter made out of special cloth, with large surface and high filtering capacity, inlet socket with contacts.

motor power	kW	2.2
	HP	3
depression	mbar	320
airflow	m ³ /h	306
supply voltage	V	380-400
socket voltage	V	12
capacity of dust container	lit	38
filter surface	cm ²	5.700
weight	kg	81
noisiness	dB	68
height of vacuum cleaner	cm	161
width of vacuum cleaner	cm	40
depth of vacuum cleaner	cm	54

Central vacuum cleaner model DS Super Compact 4,5 Turbo three phase, for two operators Code 6408



Central vacuum cleaner in sheet metal housing painted in epoxy powder with three phase lateral turbine channel, without transmissions and with approved magneto thermal motor safety switch, frequency converter and transducer*, filter chamber, removable dust container, silencer, control panel, electronic device for the variation of the motor speed, circuit board with 12 Volt inlets control and vacuum gauge, manual filter shaking device, star filter made out of special cloth, with large surface and high filtering capacity, inlet socket with contacts.

This model is equipped with an electronic inverter, which automatically adjusts the motor power (keeping constant the depression and varying the airflow), according to the:

- No. of operators;
- Pipeline network and flexible hose
- Surface to vacuum
- Kind of brush

motor power	kW	2.2- 4.5
	HP	3-6
depression	mbar	320-380
airflow	m ³ /h	231-360
supply voltage	V	380-400
socket voltage	V	12
capacity of dust container	lit	38
filter surface	cm ²	7,100
weight	kg	85
noisiness	dB	68
height of vacuum cleaner	cm	161
width of vacuum cleaner	cm	40
depth of vacuum cleaner	cm	54

Please notice:

only a technician authorized by Disan may program the software of the frequency converter.

Main parts

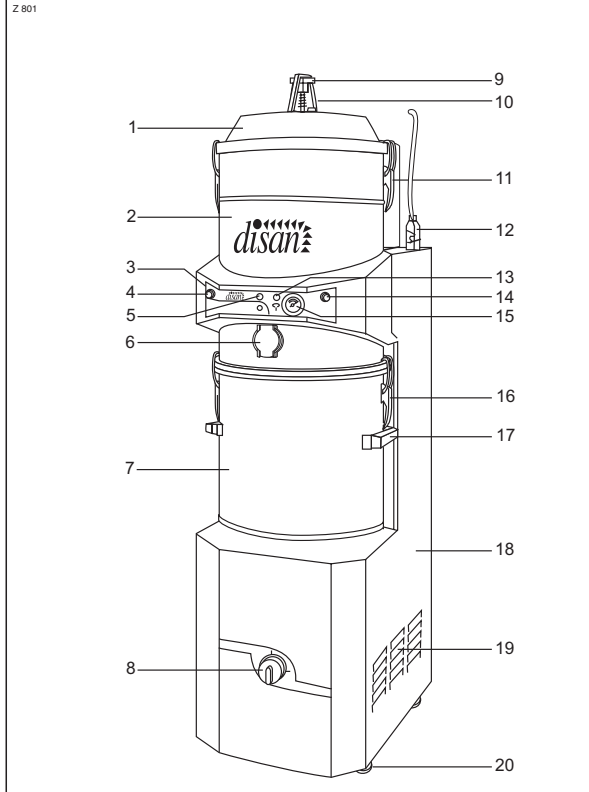

- 1. Lid
- 2. Filter chamber
- 3. Control panel
- 4. Motor "test" switch
- 5. Light signalling connection to mains

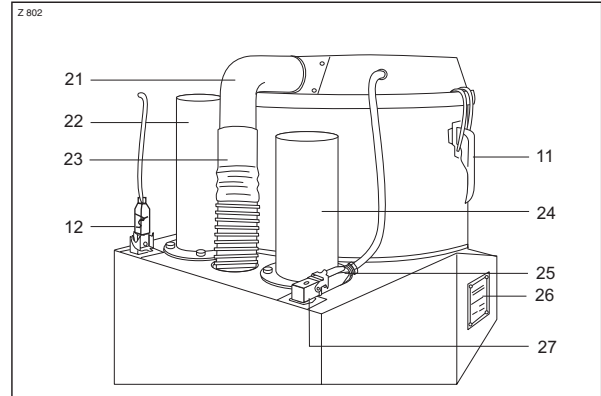

- 6. Inlet socket with contacts
- 7. Dust container
- 8. Main switch
- 9. Knob for manual filter shaking
- 10. Bracket blocking the knob for manual filter shaking
- 11. Lid locking hook
- 12. 12 volt line connection plug
- 13. Light signalling filter clogging
- 14. "Test" switch for automatic filter shaking device
- 15. Vacuum gauge for filter clogging control
- 16. Container locking hook
- 17. Handle of dust container
- 18. Chassis of filter chamber
- 19. Motor ventilation slots
- 20. Feet
- 21. Lid fitting
- 22. Vacuum tube to inlet sockets
- 23. Tube connecting motor and lid fitting
- 24. Breather pipe
- 25. Plug for automatic filter shaking device (optional)
- 26. Identification data plate
- 27. Socket for automatic filter shaking device (optional)

LIST OF OPTIONALS

- Filter self-cleaning device with circuit board. This device permits the automatic, daily cleaning of the filter, thereby always guaranteeing its full vacuum efficiency. Code IS91

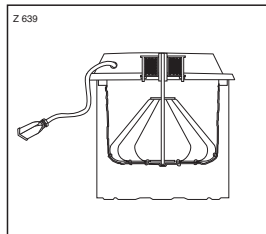

- Plastic bags for dust collection, 20-piece-package. Code ER628

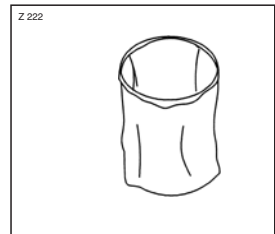

- Supporting bracket for wall fixing, including template. Code IS90

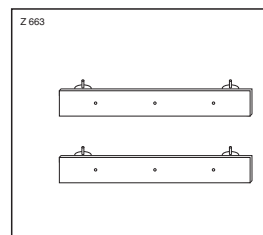

For their installation, please see the instructions attached to each optional.

INSTALLATION OF THE CENTRAL VACUUM CLEANER

The central vacuum cleaner must be installed and hooked up by an authorized installer. Instructions for a correct installation of the system are given in

the corresponding handbook "DESIGN - INSTALLATION - INSPECTION OF DS SUPER COMPACT AND DS MODULAR SYSTEMS".

ORDINARY MAINTENANCE (by the person in charge of the central vacuum cleaner)

Periodic filter cleaning

The system works perfectly only if the filter in the filter chamber is cleaned with particular care. Cleaning operations are carried out when the system is switched off.

If you intend to empty the dust container or the plastic bag after cleaning, first operate the filter cleaning devices and then wait a few minutes for the dust to deposit on the bottom of the container.

Manual operation

Manual cleaning of the filter must be carried out at regular time intervals, depending on the use of the system (e.g. every 1-2 week(s) if the system is used daily), before emptying the dust container or in any case if you notice a reduction in suction power. Anyhow, filter clogging is signalled on the filter efficiency manometer (15) on the control panel of the central vacuum cleaner as well as by the red light (8).

If the hand of the manometer is to the right (green area) the filter is in good conditions. If the hand moves to the left (red area), the filter is blocked and this causes a reduction in its filtering capacity.

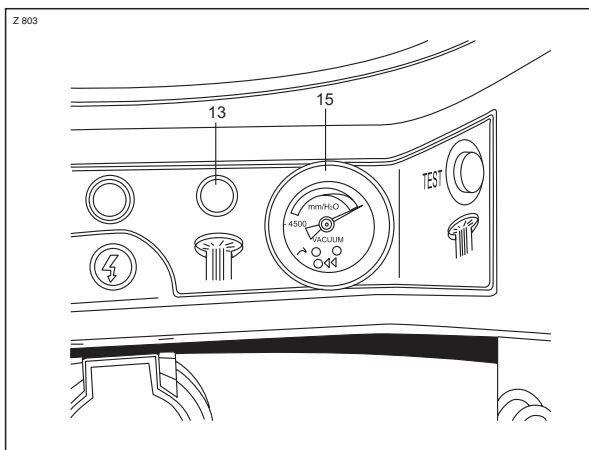

Sequence procedure

1. Lower the blocking bracket (10).
2. Energetically raise and lower the knob (9) with one hand, several times (approx. 10-15 times).
3. Bring back the blocking bracket (10) to its original position.

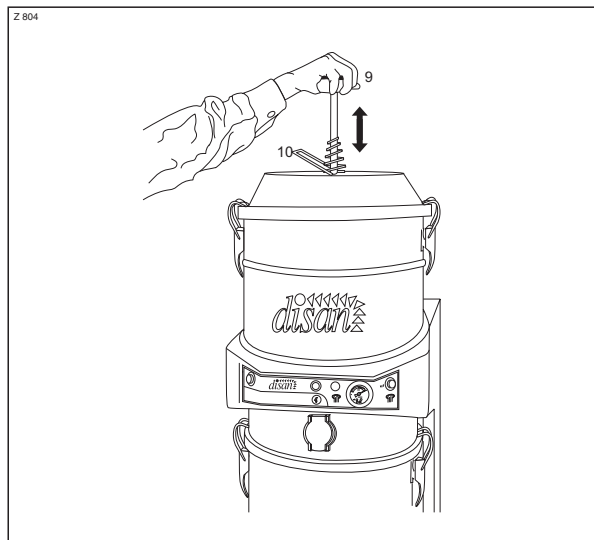

Filter self-cleaning system

An automatic filter shaking device (optional) is available for DS Super Compact central vacuum cleaners, ensuring the automatic self cleaning of the filter every 12 hours.

- To start the command-operated filter shaking device, press the "Test" switch (14) on the control panel of the central vacuum cleaner. We suggest performing this operation before emptying the dust container and in any case if you notice a reduction in suction power.
- The automatic shaking device works only when the system is switched off.

Please notice: shaking times exceeding one minute do not improve cleaning but do contribute to an early wear of the filter.

Central vacuum systems

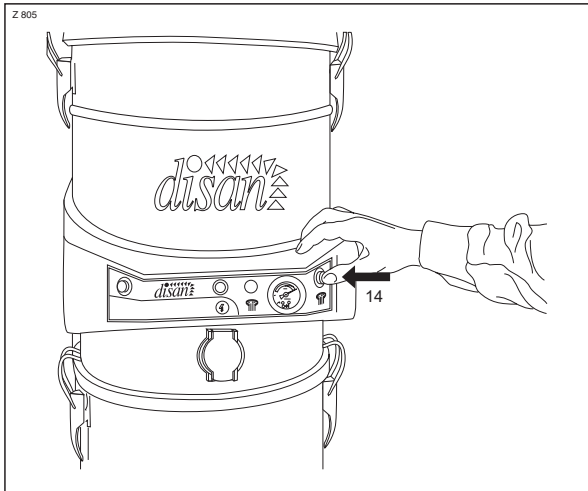

Emptying the dust container

It is essential to control the dust level every month. Dust may be collected directly in the container or in the plastic bag fitting this purpose. If necessary, dispose of the dust in compliance with the rules envisaged for separate waste collection and replace the bag. Before emptying, shake the filter (see "Period filter cleaning" on page 8). Wait a few minutes for the dust to deposit on the bottom of the container.

Sequence procedure

1. Release the dust container from the central vacuum cleaner, intervening on the corresponding locking hooks (16)



2. Grab the handles (17) and extract the container (7). Empty the container (or replace the plastic bag, if any).

Code ER628 Plastic bag

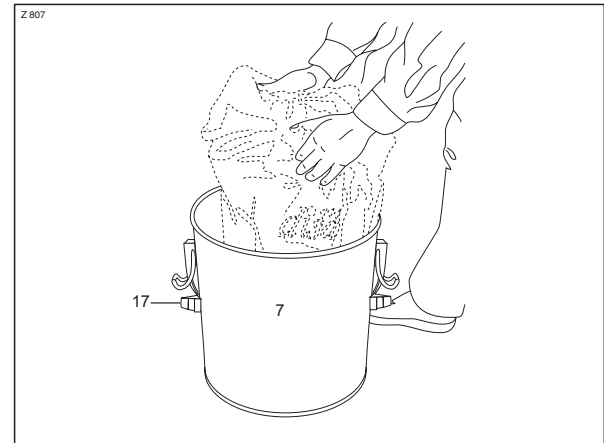

3. Reinsert the container (7) and close the locking hooks (16) in their original position so that it fits tightly again in the filter chamber (2).

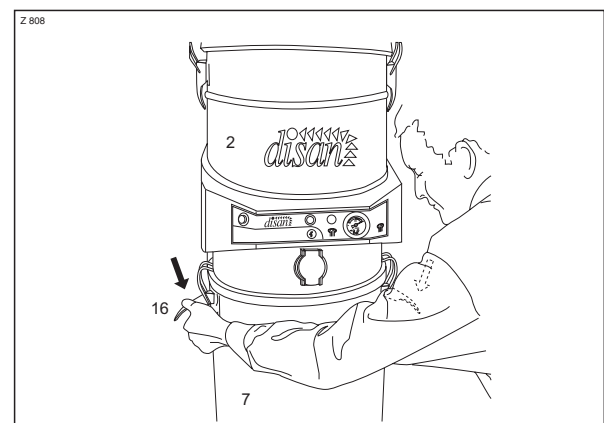

Central vacuum systems

Check of the automatic filter shaking device

Check whether the filter shaking device works properly:

1. Keep pressed for a few seconds button (14) on the control panel of the central vacuum cleaner.
2. If noisiness or the emission of vibrations is higher than normal or in any case excessive, contact the installer.

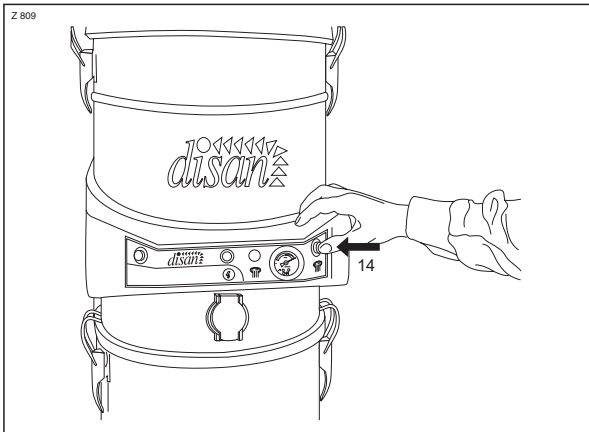

Check of the turbine

Check whether the turbine works properly:

1. Keep pressed for a few seconds button (4) on the control panel of the central vacuum cleaner.
2. If noisiness or the emission of vibrations is higher than normal or in any case excessive, contact the installer.

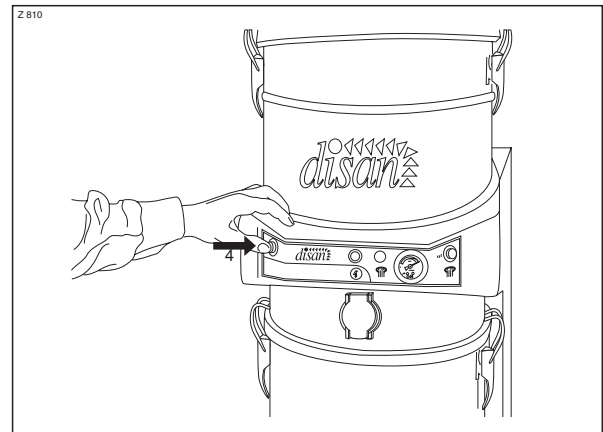

EXTRAORDINARY MAINTENANCE (by the installer)

Perform the following controls every year:

Filter control and replacement

Stages to disassemble the lid:

While the system is switched off, detach the hose (23) from the lid fitting (21). Lower the blocking device (10). Unblock the locking hooks (11) and lift the lid (1) together with the filter (27).

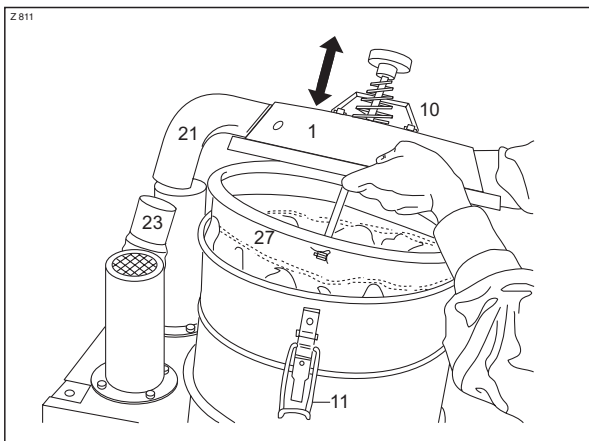

If there is an automatic filter shaking device, disconnect the plug (25) from the socket (26) on the back of the central vacuum cleaner.

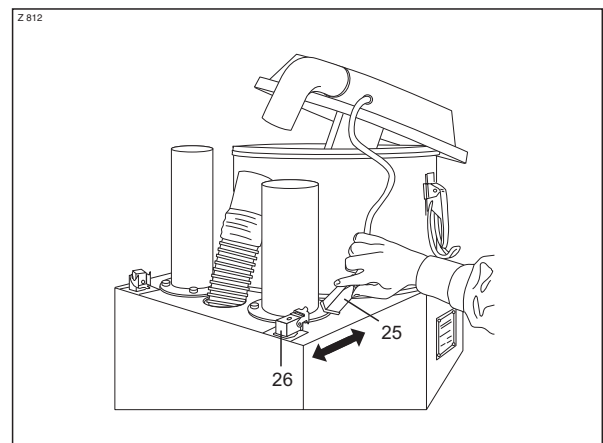

Central vacuum systems

- **Checking the filter conditions:** check whether the internal surface of the filter is completely white. If it isn't, the filter is probably pierced. Check whether there are holes. To check, follow the steps necessary to disassemble the lid and the filter.

- **Filter cleaning:** if the internal surface of the filter is white while the external one is excessively dirty, clean it with a brush, a compressor or a traditional vacuum cleaner. The filter can also be cleaned by washing it in a washing machine at low temperatures. To clean the filter, follow the steps necessary to disassemble the lid and the filter.

- **Filter replacement:** if the filter is pierced and therefore no longer usable, put it in a plastic bag, close it and dispose of it in compliance with the rules for separate waste collection. Replace the filter as described below.

Please notice: using a filter which is different from the replaced one, entails replacing the filter housing.

Steps for filter dismantling:

• Model DS SUPER COMPACT 1,5 and DS SUPER COMPACT 2,2

1. Unscrew the clamp (29) which holds the filter (27) onto its housing and detach the two parts.
2. Unscrew the clamp (30) from the filter ring (31), remove it from the filter and set aside.

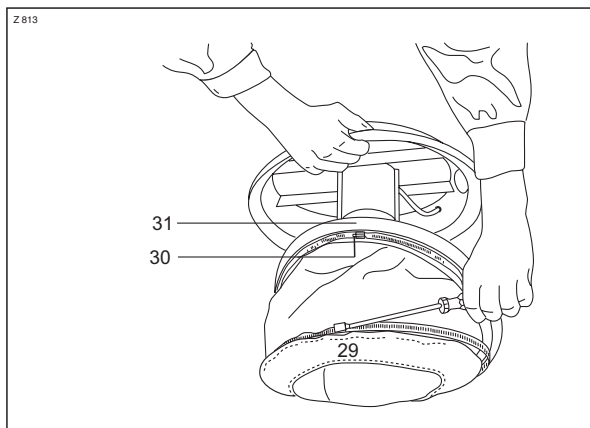

• Model DS Super Compact 4,5 Turbo

1. Turn the filter (27) upside down to expose the fixing clamps (32).
2. Cut the clamps (32) and detach the housing (33) from the filter (27).
3. Unscrew the clamp (30) from the filter ring (31), remove it from the filter and set aside.

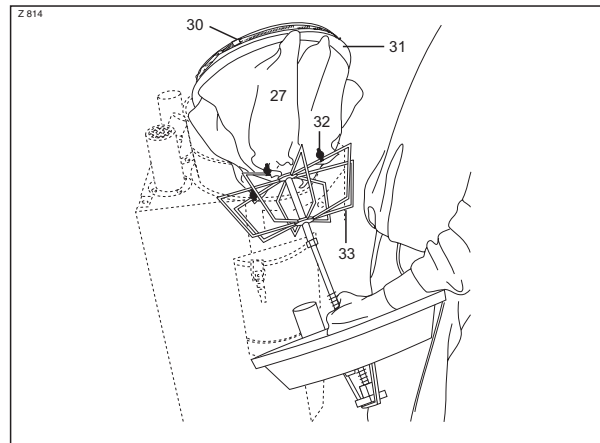

! WARNING !

The filter must be carefully replaced. It must be replaced by another filter with the same characteristics, otherwise you risk jeopardising the correct operation of the vacuum cleaner.

• Filter with a 360 mm diameter for the models DS SUPER COMPACT 1,5 and DS SUPER COMPACT 2,2
Code 32-101

• Star filter with a 360 mm diameter for the model DS SUPER COMPACT 4,5 TURBO
Code 32-001

Steps for filter and lid mounting onto the central vacuum cleaner:

Mount the filter and the lid onto the central vacuum cleaner following in reverse sequence the procedure indicated for the disassembly of the filter and of the lid.

INLET SOCKET ON THE CENTRAL VACUUM CLEANER

The DS Super Compact central vacuum cleaner is equipped with an inlet socket on the filter chamber to vacuum-clean the room where the central vacuum cleaner itself is placed.

Open the flap door of the socket and insert the fitting of the hose. When cleaning is over, take out the fitting and close the socket's flap door.



SAFETY INSTRUCTIONS (read carefully)

Failed observance of the safety instructions may compromise the operation of the system or seriously damage it. The following "safety instructions" contain essential indications for the system's safety and for the safety of the people using it.

System's safety prearranged during its production

The vacuum cleaner was made paying particular attention to the safety of operators. Each component was designed on the basis of strict safety guarantees which *Disan* has adopted.

Electrical safety

- ☞ Connect the central vacuum cleaner only to a current with the same tension indicated on the "identification data" plate (see chapter "IDENTIFICATION DATA", page 14).
- ☞ Establish the electrical connection to a supply mains with efficient grounding and with a neutral phase.
- ☞ The safety of the electronic system is guaranteed only if there is a suitable safety ground fault circuit-breaker complying with the regulations in force.

System's safety

- ☞ Before using it for the first time, make sure – via the installer - that the entire system works perfectly.

- ☞ Do not expose the central vacuum cleaner to the direct action of the weather (e.g. rain, snow etc.).
- ☞ Do not wash the central vacuum cleaner with water jets, do not dip it in water.
- ☞ Check at regular time intervals the dust container or the plastic bag, if any (see paragraph "Emptying of the dust container", page 9).
- ☞ At regular time intervals, shake the filter manually (see paragraph "Periodic filter cleaning", page 8).
- ☞ Never vacuum-clean without having the filter installed and, under any circumstance, use only original *Disan* filters.
- ☞ Do not start the system during failure.

Technical assistance

- ☞ If the green light signalling connection to the mains (at the centre of the control panel) remains on and if the causes of the failed operation cannot be found among those listed in the "TABLE OF FAILURES", page 13, please contact your dealer or an authorised installer.
- ☞ Any intervention must be carried out only when the system is switched off and disconnected from the mains.
- ☞ We suggest checking the system and overhauling the central vacuum cleaner every 4-5 years.

! WARNING !

Safety devices must never be tampered with!

TROUBLESHOOTING YOUR CENTRAL VACUUM SYSTEM

SYMPTOM							CAUSE
The inlet socket whistles	No vacuum power	Low vacuum power	The system does not start	The system remains on	The system turns on and off intermittently	The ground fault circuit-breaker trips	
		✓					1. Filter clogging
	✓	✓					2. Hose clogging
		✓					3. Wrong closing of the dust container – cyclone's gasket (optional) damaged or out of place
		✓					4. Simultaneous use of several inlet sockets
	✓	✓					5. Tubes clogging
	✓		✓				6. Thermal safety device
	✓		✓	✓	✓		7. Defective or dirty microswitch of the socket
			✓				8. Wear of the inlet socket's contacts
	✓		✓				9. 12 volt mains lead to inlet sockets is damaged
	✓		✓	✓			10. Defective circuit board – motor failure
	✓		✓	✓	✓		11. Hose with on-off switch
	✓					✓	12. Excessively high absorption (kW) by household appliances
		✓					13. Insufficient or excessively high supply tension (volt) of the mains
	✓	✓					14. Dust container full
✓		✓					15. Defective gasket of the inlet socket – protruding screws
			✓				16. Insufficient diameter of supply cables
			✓				17. Insufficient amperage of the ground fault circuit-breaker

1. FILTER CLOGGING

If suction power at the inlet socket is low, the filter may be excessively clogged. You can see this from the manometer placed on the control panel of the central vacuum cleaner which, when the motor is started, moves to the red area.

In this case:

if the machine has a manual shaking device, clean it as indicated on page 8; if it equipped with an automatic shaking device, see page 8.

2. HOSE CLOGGING

If the suction power at the inlet socket is good, clogging is in the hose or in the brushes. If – on the contrary - suction power at the inlet socket is weak, clogging is

- a. in the socket (visible to the naked eye)
- b. in the tubing (see item 5)

If necessary, clean them manually (for precaution, wear latex gloves, as those used in the kitchen).

3. WRONG CLOSING OF THE DUST CONTAINER – CYCLONE'S GASKET (OPTIONAL) DAMAGED OR OUT OF PLACE

After emptying, make sure that the dust container closes tightly to avoid suction power reductions.

Furthermore, check that the gasket is positioned correctly and that it is not damaged.

4. SIMULTANEOUS USE OF SEVERAL INLET SOCKETS

The models DS Super Compact 1,5 and DS Super Compact 2,2 are designed for use by a single person. The simultaneous use of several inlet sockets on the same network entails a considerable suction power reduction.

The model DS Super Compact 4,5 Turbo is suitable for use by two people simultaneously.

5. TUBES CLOGGING

If the procedures listed under 1,2,3 and 4 do not increase the air flow rate, clogging is in the tubing. In this case, contact your installer.

6. THERMAL SAFETY DEVICE

If:

- the vacuum motor has been subjected to a considerable electric current overload;
- the motor is defective;
- the motor has overheated due to filter clogging, clogging of the tubing or a narrowing in the breather pipe

Central vacuum systems

1) Models DS Super Compact 1,5 and 2,2

The main switch (with thermal safety device) trips. Before switching it on again, wait 8-10 minutes for the motor to cool down.

2) Model DS Super Compact 4,5 Turbo

The system turns off when the inverter intervenes. Switch off the main switch (8) (see page 7) on the central vacuum cleaner. Wait one minute, then switch on the main switch (8). Wait 8-10 minutes for the motor to cool down.

If after completing the procedures as of items 1, 2 and 5 the thermal safety device continues to trip, switch the system off and contact your installer.

7. DEFECTIVE OR DIRTY MICROSWITCH OF THE SOCKET

If the central vacuum cleaner remains switched on or does not start despite the closing or opening of the inlet socket, check whether the microswitch on the socket itself works properly. If you cannot find the cause, contact your installer.

8. WEAR OF THE INLET SOCKET'S CONTACTS

If the system does not start and you use inlet sockets with contacts, check whether the contacts are worn.

9. 12 VOLT MAINS LEAD TO INLET SOCKETS IS DAMAGED

It happens rarely that the mains lead connecting the inlet sockets to the central vacuum cleaner gets damaged. Contact your installer.

10. DEFECTIVE CIRCUIT BOARD – MOTOR FAILURE

If the procedures listed above do not start the vacuum motor, the cause lies in the burning out of the transformer, of the relay or in a motor failure. Contact your installer.

11. HOSE WITH ON-OFF SWITCH

If you use a hose with an on-off switch on its handgrip and the system does not start, remains switched on or switches on and off intermittently, create a bridge between the two contacts (12 volt) in the socket. If the system starts, the cause is in the hose. Contact your installer.

12. EXCESSIVELY HIGH ABSORPTION (KW) BY HOUSEHOLD APPLIANCES

If the system does not start, if its main switch trips or the ground fault circuit-breaker trips (perhaps due to the simultaneous use of several household appliances) the mains power supply (kW) is insufficient. Switch off a household appliance to continue working and - if necessary - ask the utility company to increase the power supply (kW) to your system.

13. INSUFFICIENT OR EXCESSIVELY HIGH SUPPLY TENSION (VOLT) OF THE MAINS

Have the tension of the mains checked, to verify that it is not lower or does not exceed by 5% the tension indicated on the identification plate (see next page "Identification data plate").

14. DUST CONTAINER FULL

Empty the container (see page 9 "Emptying of the dust container").

15. DEFECTIVE GASKET OF THE INLET SOCKET – PROTRUDING SCREWS

Replace the gasket or tighten the screws correctly.



16. INSUFFICIENT DIAMETER OF SUPPLY CABLES

If you use the model DS Super Compact 1,5 and the system does not start, check whether the supply mains lead square measure is at least 2.5 mm².

17. INSUFFICIENT AMPERAGE OF THE GROUND FAULT CIRCUIT-BREAKER

If you use the model DS Super Compact 4,5 Turbo, a ground fault circuit-breaker with a FI value of at least 300 mA is required.

Clogging of the tubes □ air infiltrations

DIAGNOSIS	PROGNOSIS	REMEDY
 <p>Drop in suction power</p>	clogged	1A Open the dust container 1B Vacuum the other way round, connecting a powerful vacuum cleaner to the inlet sockets 2 Explore the tubes with a spiral probe (used for plumbing works) 3 Contact <i>Disan's</i> technical office
 <p>insufficient depression</p>	air infiltrations	1A If there is no noise, switch on the system keeping the inlet sockets closed 1B Locate the source of whistling due to air infiltrations 2 Use the suitable inspection camera (code GE903) 3 Contact <i>Disan's</i> technical office

IDENTIFICATION DATA

Position of the identification data plate

The position of the identification data plate indicating the machine's data is as shown in the picture:

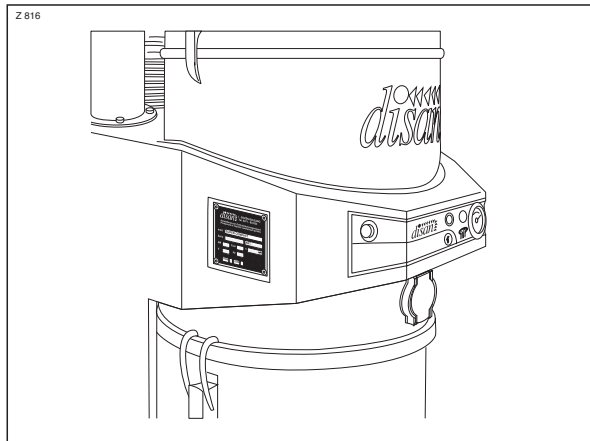

Data on the plate

All technical and construction data pertaining to your central vacuum cleaner are indicated on the identification plate.

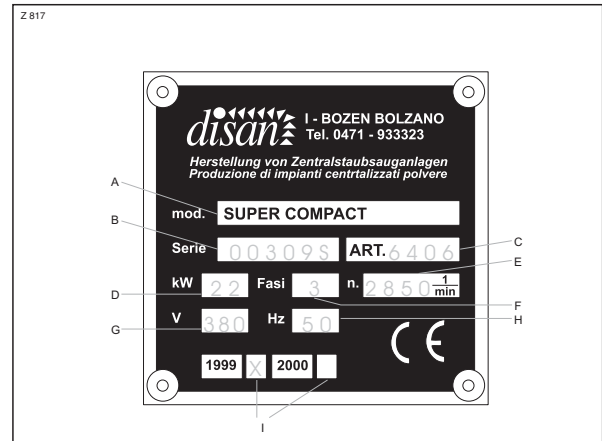

- A = vacuum cleaner's model
- B = serial number
- C = article code
- D = motor absorption (kW)
- E = number of revolutions per minute of the motor
- F = motor's stages
- G = supply tension (V)
- H = operating frequency (Hz)
- I = year of construction

Data identification for assistance or guarantee purposes

Every time you contact Disan's "technical assistance service" or the installer, specify the data of your machine. A clear indication of the "machine's model" and of the "serial number" will help the constructor answering you and will avoid inaccuracies or mistakes. Please refer to the data indicated in your guarantee certificate (see last page).

CHECK LIST FOR THE INSTALLER

- Check of inlet socket's tightness
 - Check of the turbine's operation
 - Check of the starting of the system at the inlet sockets
 - Filter check and cleaning
 - Check of the wear of vacuum cleaning accessories
 - Check of the operation of the automatic filter shaking device*
 - Check of the suction value
- * if available

YEARLY MAINTENANCE CONTRACT

We suggest entrusting your installer with the yearly maintenance in order to always keep the system at its maximum efficiency.

LAYOUT DS SUPER COMPACT 1,5 - 2,2 MODELS

Z 818

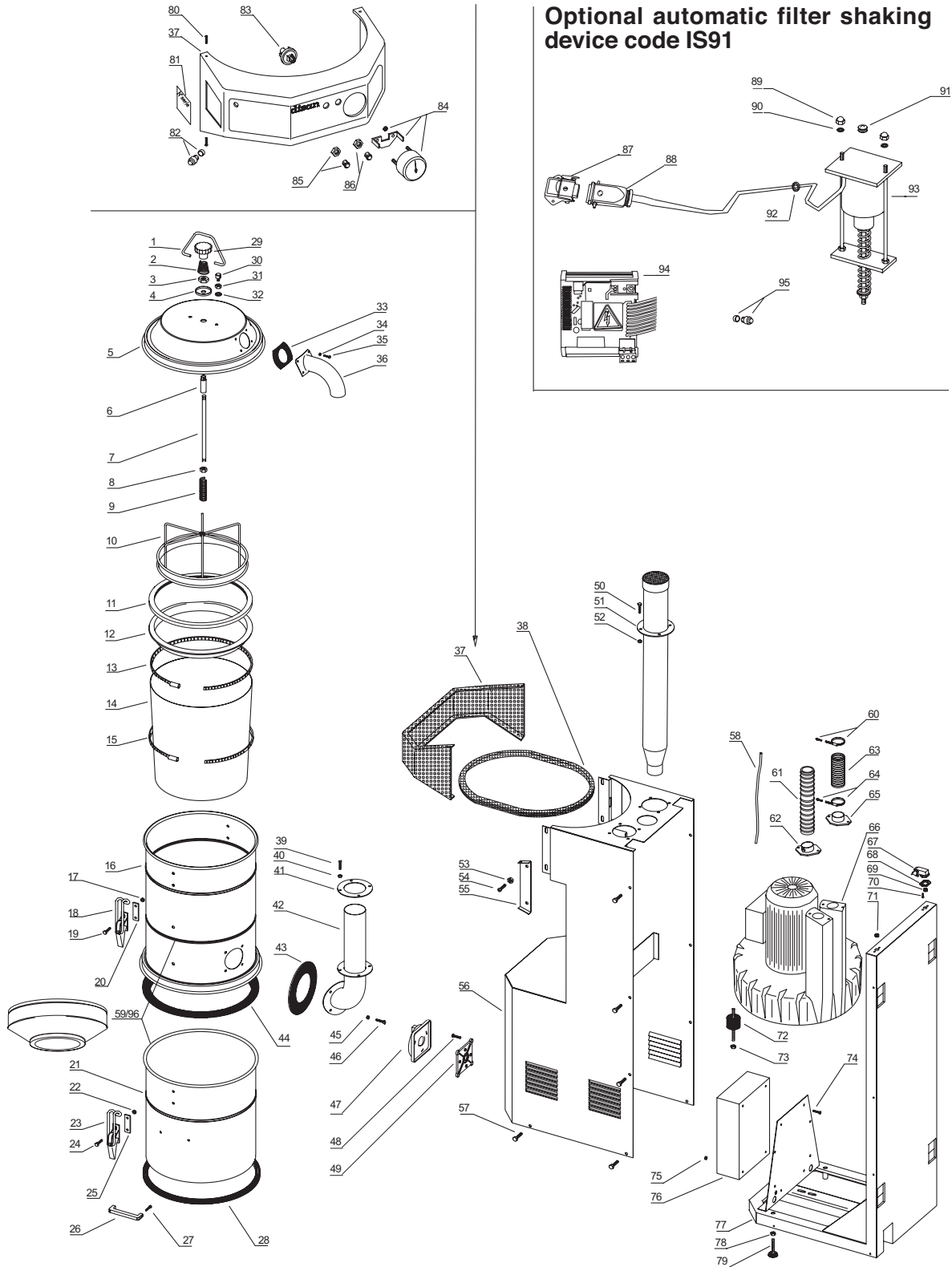

SPARE PARTS FOR THE DS SUPER COMPACT 1,5 - 2,2 MODELS

1	Spring blocking hook	30-103	51	Silencer	25-005
2	External spring for manual filter shaking device	30-211	52	M6 nut	61-011
3	M18 nut	61-082	53	M8 nut	61-021
4	Spring holder	30-201	54	Screw M8 x 16	60-031
5	Lid	20-501	55	Plate of cover bearing element	23-503
6	Threaded bush	30-101	56	Cover of supporting frame	23-502
7	Galvanised pin	30-102	57	Screw M6 x 15	60-021
8	M12 nut	61-083	58	Cable	82-102
9	Internal spring for manual filter shaking device	30-213	59	Rubber fitting	24-741
10	Lower filter blocking ring	30-003	60	Tube clamp	62-101
11	Gasket for bag blocking ring	40-101	61	Tube	25-301
12	Upper filter blocking ring	30-001	62	Tube – motor connection fitting	10-901
13	Upper filter blocking clamp	62-111	63	Tube	25-301
14	Tubular filter	32-101	64	Tube clamp	62-101
15	Lower filter blocking clamp	62-111	65	Tube – motor connection fitting	10-901
16	Cylinder	23-001	66A	1.5 KW motor	10-201
17	M6 nut	61-011	66B	2.2 KW motor	10-301
18	Lid closing device	69-001	67	12 volt plug	85-201
19	Screw M6 x 10	60-511	68	Gasket for 12 volt plug	85-201
20	Bearing of lid closing device	69-001	69	M3 nut	85-201
21	Lower collection element	24-501	70	Screw M3 x 16	60-002
22	M6 nut	61-011	71	Rubber cap	41-101
23	Closing device for collection element	69-001	72A	Shock absorber for 1.5 KW motor	69-201
24	Screw M6 x 10	60-511	72B	Shock absorber for 2.2 KW motor	69-202
25	Bearing of closing device for collection element	69-001	73A	M8 nut	61-021
26	Handle	69-002	73B	M10 nut	61-031
27	Screw for handle	60-007	74	Screw M4 x 12	60-012
28	Gasket for collection element	40-111	75	M4 nut	61-001
29	Knob	50-201	76A	Control box for 1.5 KW motor	87-001
30	Screw for spring blocking hook	30-103	76B	Control box for 2.2 KW motor	87-001
31	Washer for spring blocking hook	30-103	77	Bearing frame	23-501
32	Nut for spring blocking hook	30-103	78	M10 nut	61-031
33	Gasket for cylinder tube	41-001	79	Foot	50-101
34	M4 nut	61-001	80	Screw 3,5 x 10	60-012
35	Screw M4 x 12	60-012	81	Identification data plate	99-551
36	Lid tube	25-001	82	Switch for motor test	81-501
37	Control panel	50-002	83	Pressure switch	89-101
38	Gasket for control panel	40-112	84	Complete vacuum gauge	89-001
39	Screw M6 x 15	60-021	85	Green light	88-002
40	M6 nut	61-011	86	Red light	88-001
41	Flange	25-003	87	Socket 12 volt mains lead for filter shaking device	85-203
42	Cylinder tube	25-002	88	Plug 12 volt mains lead for filter shaking device	85-202
43	Gasket for cylinder tube	41-002	89	Fixing nut for filter shaking device	61-023
44	Gasket for cylinder	40-011	90	Fixing washer for filter shaking device	61-522
45	M6 nut	61-011	91	Rubber cap	41-101
46	Screw M6 x 15	60-021	92	Gasket for shaking device cable	41-102
47	Switch	81-003/81-001	93	Shaking element	30-100
48	Screw M3,5 x 10	60-012	94	Circuit board for automatic filter shaking device	80-201
49	Switch holder	81-003/81-001	95	Switch for filter shaking device test	81-501
50	Screw M6 x 15	60-021	96	Lower Cyclon	24-731

LAYOUT DS SUPER COMPACT 4,5 TURBO MODEL

Z 819

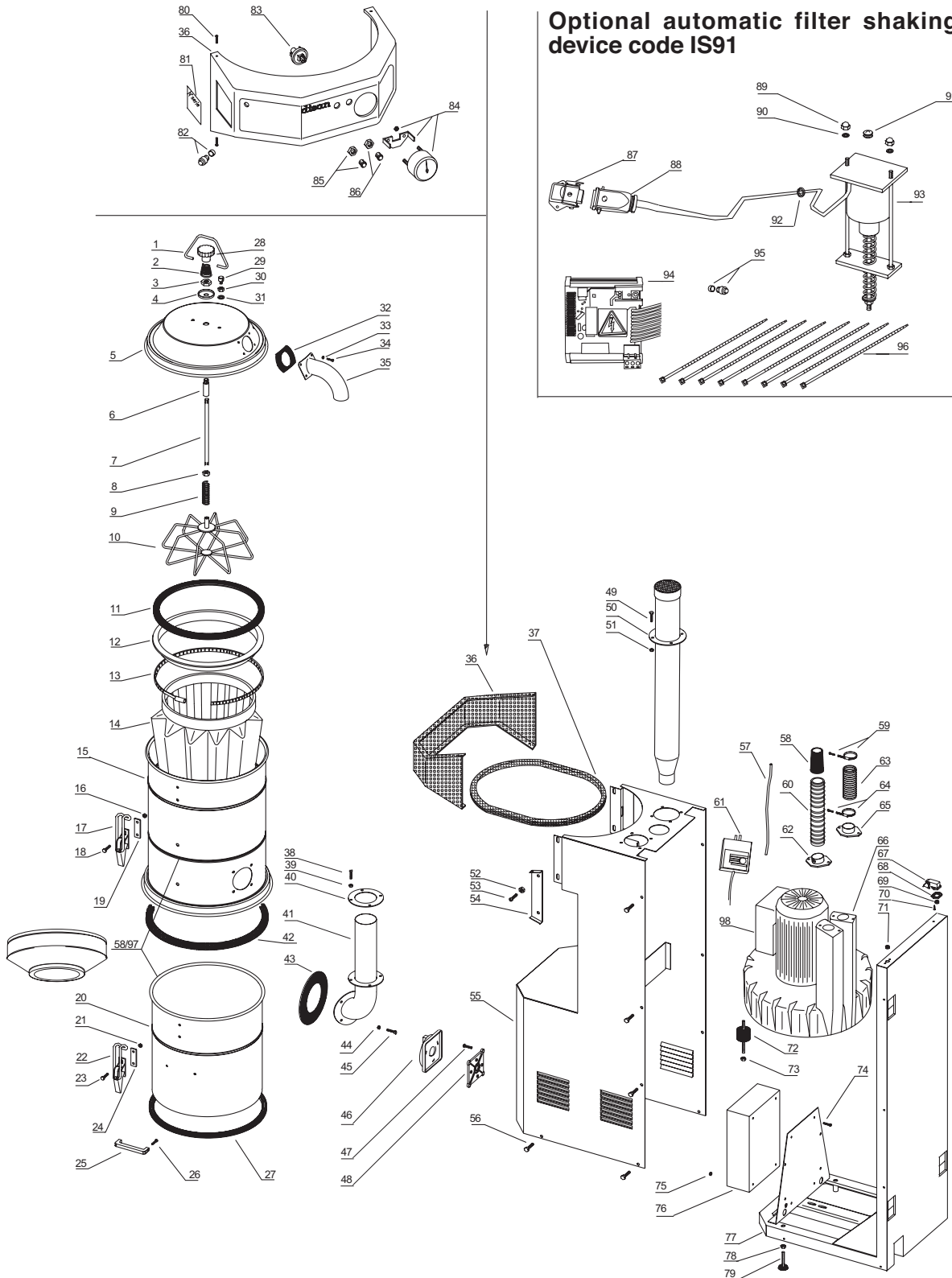

SPARE PARTS FOR THE DS SUPER COMPACT 4,5 TURBO MODEL

1	Spring blocking hook	30-103	49	Screw M6 x 15	60-021
2	External spring for manual filter shaking device	30-211	50	Silencer	25-005
3	M18 nut	61-082	51	M6 nut	61-011
4	Spring holder	30-201	52	M8 nut	61-021
5	Lid	20-501	53	Screw M8 x 16	60-031
6	Threaded bush	30-101	54	Plate of cover bearing element	23-503
7	Galvanised pin	30-102	55	Cover of supporting frame	23-502
8	M12 nut	61-083	56	Screw M6 x 15	60-021
9	Internal spring for manual filter shaking device	30-213	57	Cable	82-102
10	Star bag stretching ring	30-002	58	Rubber fitting	24-741
11	Gasket for bag blocking ring	40-101	59	Tube clamp	62-101
12	Upper filter blocking ring	30-001	60	Tube	25-301
13	Upper filter blocking clamp	60-111	61	Depression transducer	89-202
14	Star filter	32-001	62	Tube – motor connection fitting	25-401
15	Cylinder	23-001	63	Tube	25-301
16	M6 nut	61-011	64	Tube clamp	62-101
17	Lid closing device	69-001	65	Tube – motor connection fitting	10-901
18	Screw M6 x 10	60-511	66	Motor for inverter	10-401
19	Bearing of lid closing device	60-511	67	12 volt plug	85-201
20	Lower collection element	24-501	68	Gasket for 12 volt plug	85-201
21	M6 nut	61-011	69	M3 nut	85-201
22	Closing device for collection element	69-001	70	Screw M3 x 16	60-002
23	Screw M6 x 10	60-511	71	Rubber cap	41-101
24	Bearing of closing device for collection element	60-511	72	Shock absorber for motor	69-202
25	Handle	69-002	73	M10 nut	61-031
26	Screw for handle	60-007	74	Screw M4 x 12	60-012
27	Gasket for collection element	40-111	75	M4 nut	61-001
28	Knob	50-201	76	Control box	87-001
29	Screw for spring blocking hook	30-103	77	Bearing frame	23-501
30	Washer for spring blocking hook	30-103	78	M10 nut	61-031
31	Nut for spring blocking hook	30-103	79	Foot	50-101
32	Gasket for cylinder tube	41-001	80	Screw 3,5 x 10	60-012
33	M4 nut	61-001	81	Identification data plate	99-551
34	Screw M4 x 12	60-012	82	Switch for motor test	81-501
35	Lid tube	25-001	83	Pressure switch	89-101
36	Control panel	50-002	84	Complete vacuum gauge	89-001
37	Gasket for control panel	40-112	85	Green light	88-002
38	Screw M6 x 15	60-021	86	Red light	88-001
39	M6 nut	61-011	87	Socket 12 volt mains lead for filter shaking device	85-203
40	Flange	25-003	88	Plug 12 volt mains lead for filter shaking device	85-202
41	Cylinder tube	25-002	89	Fixing nut for filter shaking device	61-023
42	Gasket for cylinder	40-011	90	Fixing washer for filter shaking device	61-522
43	Gasket for cylinder tube	41-002	91	Rubber cap	41-101
44	M6 nut	61-011	92	Gasket for shaking device cable	41-102
45	Screw M6 x 15	60-021	93	Shaking element	30-100
46	Switch	81-041	94	Circuit board for automatic filter shaking device	80-201
47	Screw M3,5 x 10	60-012	95	Switch for filter shaking device test	81-501
48	Switch holder	81-041	96	Fixing clamps for star filter	62-001
			97	Lower Cyclon	24-731
			98	Inverter	10-603

Guarantee certificate

To be filled in by the manufacturer

Tested by:

Model: _____

Serial number: _____

GUARANTEE CERTIFICATE
!!IMPORTANT!!

Please send us this card, filled in,
within 30 days to allow the
recording of your guarantee right.

----- ✂

Guarantee certificate

Model: _____

Date of purchase: _____

Serial number: _____

Purchaser's address: _____

12 MONTH GUARANTEE

✂

Seller's stamp and signature

GUARANTEE TERMS

Terms valid when purchased

The central vacuum cleaner has been delivered to the user under the terms in force at the time of purchase.

12 months

The **Disan** company undertakes to replace under warranty the parts which have manufacturing defects during a period of 12 months from their date of purchase.

Guarantee certificate

The guarantee is valid if the detachable coupon (see last page, GUARANTEE CERTIFICATE) is filled-in in a readable way and is returned within 30 days maximum from the date of purchase.

Contact your installer

For any abnormal condition, please contact your installer, always indicating the identification data.

Disan's reserve

For the guarantee to be acknowledged, the defective part must be sent to the Company's seat in Bolzano so that it can be tested at the technical assistance laboratories. **Disan** reserves to establish the cases when the defective parts meet the conditions allowing for a "replacement under warranty".

Expenses charged to the client

Installation, disassembly and transport expenses for the defective parts are charged to the purchaser.

Non acknowledgement:

For the guarantee to be valid, the instructions contained in this booklet have to be compulsorily followed.

Otherwise **Disan** may choose not to make the repairs. Furthermore, the manufacturer holds himself relieved from any liabilities for damage to people and things resulting from non-compliance in the following cases:

- incorrect installation;
- improper use of the central vacuum cleaner or of the accessories;
- the foreseen maintenance has not been made or has been made improperly;
- use of non original spare parts;
- total or partial inobservance of the instructions for use;
- natural wear;
- attempts to disassemble, modify or in general tamper with any component of the central vacuum cleaner by the user or unauthorised personnel;
- the guarantee certificate has not been sent in;
- non regular payment.

Competence of the Bolzano court

The Court of Bolzano (Italy) is exclusively competent for any dispute.

Please
stamp

disan®
Srl
Central vacuum systems

Via di Mezzo ai Piani 13/A
39100 BOLZANO
ITALY

